

How is Flanders doing in AI ?



Prof. Dr. Bart De Moor

Co-coordinator Flanders AI Program
Chairman athumi (Flanders Data Utility Company)

Menu

- AI: what, when, how ?
- Flanders AI Program
- Issues in 'AI in science' policies and science policy for AI
- athumi (Flanders Data Utility Company)



What is Artificial Intelligence and Machine Learning?

- Artificial intelligence
 - “Intelligence” as demonstrated by a machine unlike ‘natural (animal, human) intelligence’
 - Mimic the human mind in ‘cognitive functions’ and ‘problem solving’
 - Mimic = by massive computing power, exploiting tsunami of data
 - Inter/cross-disciplinary: mathematics, computer information science, control engineering, psychology, linguistics,...
 - Emotionality ? (Self-)consciousness ?
- Machine Learning
 - Computer algorithms that ‘improve’ their performance through experience/data processing
 - Supervised (e.g. by providing classification labels) or unsupervised (e.g. data reduction)
 - Interdisciplinary: mathematics, statistics, numerical optimization, ...
 - Training and validation data
 - Generalization, Transfer Learning, Generative AI, ...

Technology and Engineering Design: The third industrial revolution (1945...)

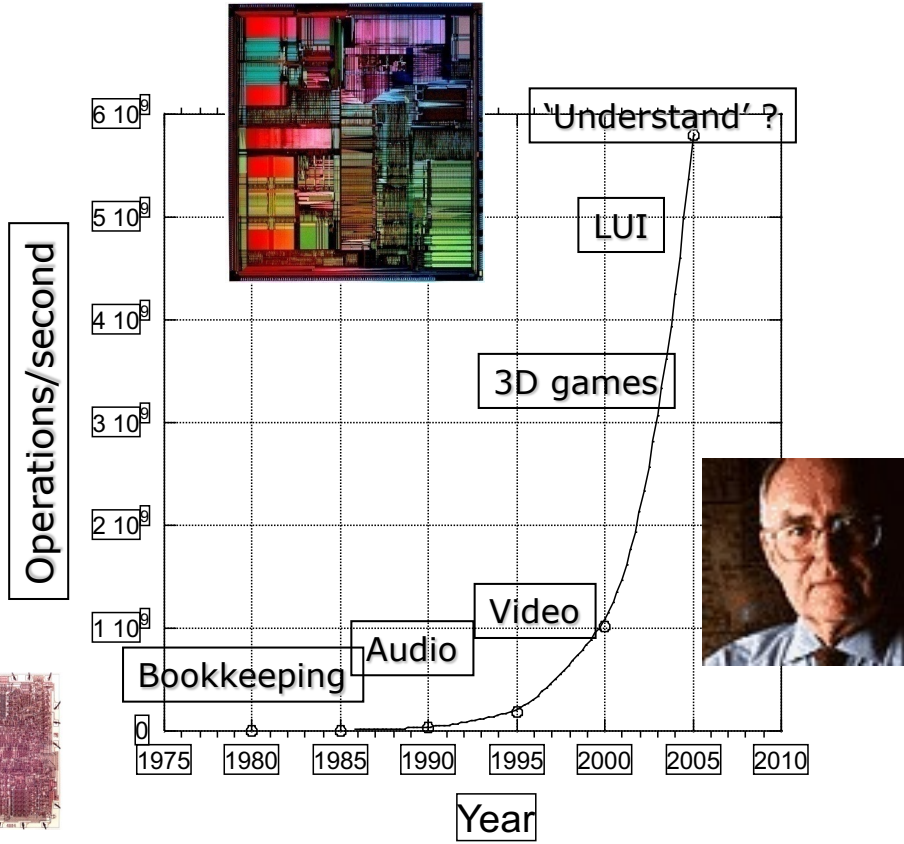
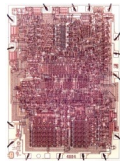
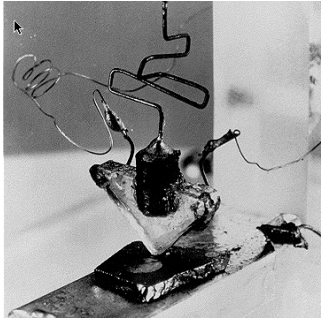

Computational power x 2 every 18 months

Neuromorphic chips ?

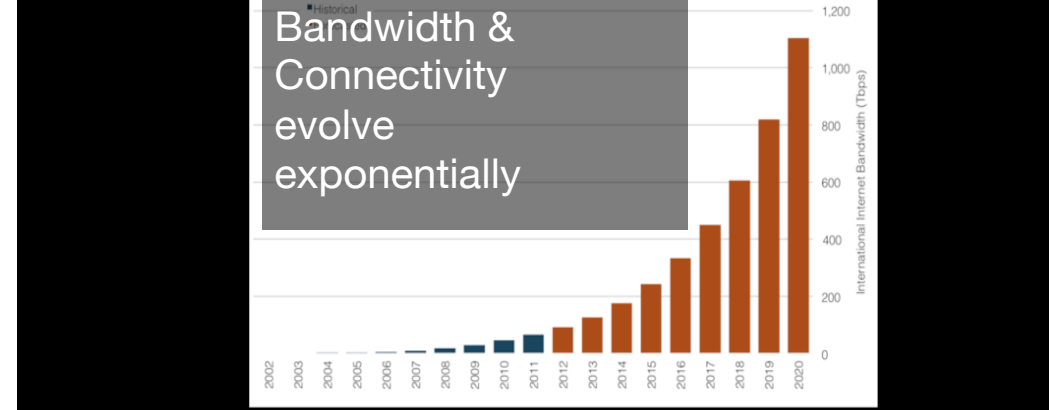

Training compute (FLOPs) of milestone Machine Learning systems over time

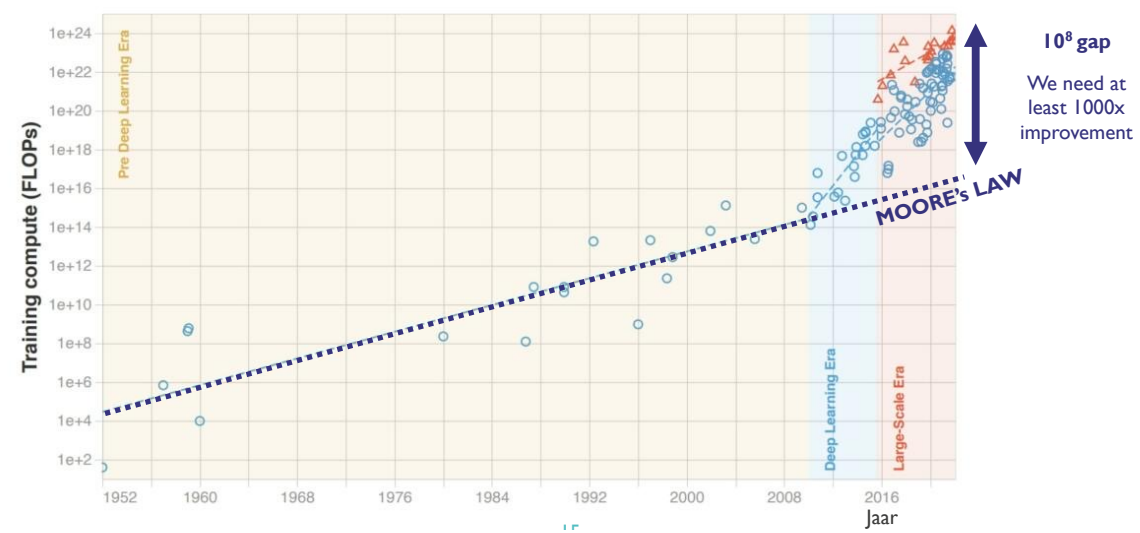

Simple Neural Network

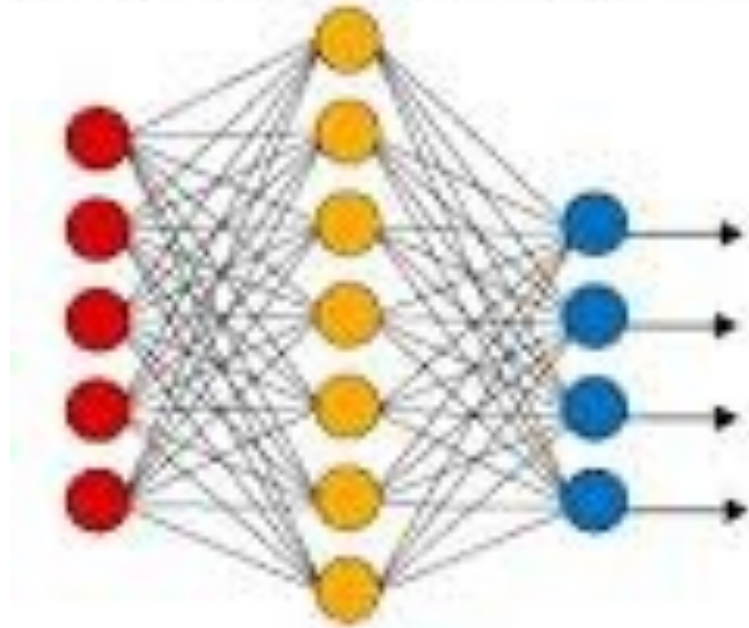

● Input Layer

Deep Learning Neural Network

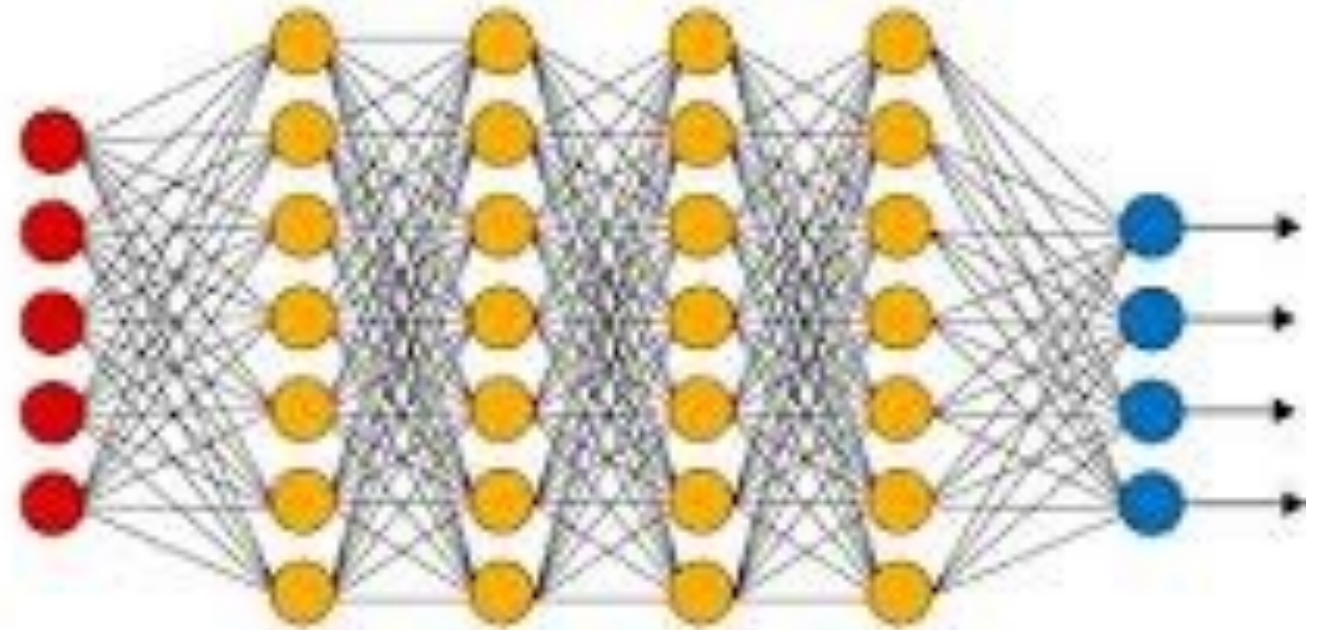

● Hidden Layer

● Output Layer

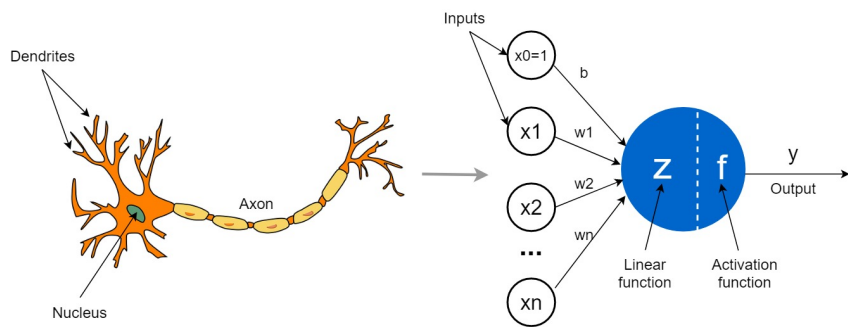

Universal approximation



Grains of rice the world consumes annually: **27.5 quadrillion**

Amount of data the world consumes every 30 minutes: **40.4 petabytes**

We consume more bytes on the internet in 30 minutes than grains of rice in a year.

1 million = 1 000 000	1 kB = 1 000	1 TB
1 billion = 1 000 000 000	1 MB = 1 000 000	= large university library
1 trillion = 1 000 000 000 000	1 GB = 1 000 000 000	= 212 DVD discs
1 quadrillion =	1 TB = 1 000 000 000 000	= 1430 CDs
1 000 000 000 000 000	1 PB = 1 000 000 000 000 000	= 3 year music CD quality

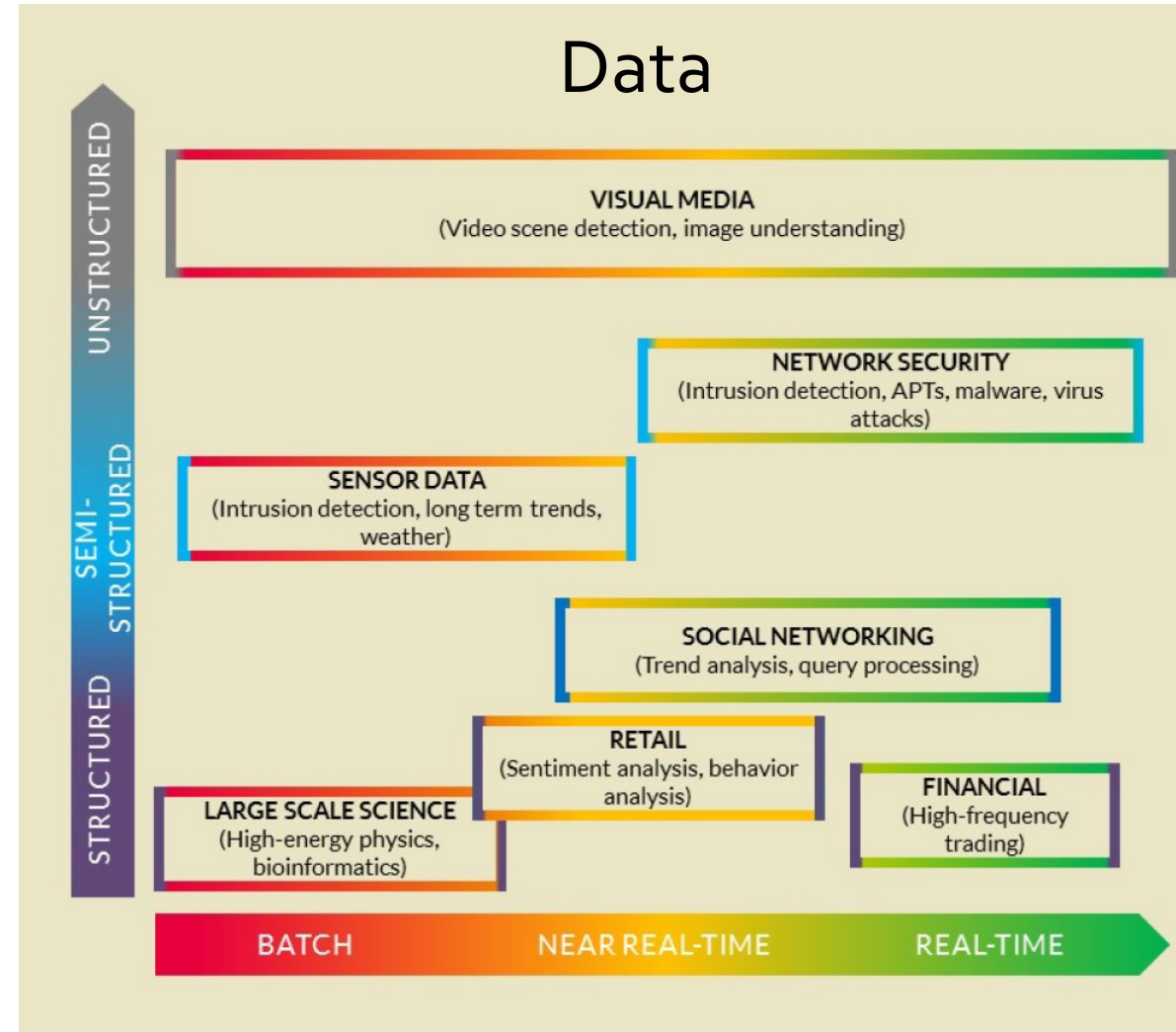

The Fourth Paradigm

Paradigm	Time Ago	Method
First	A millenium	Empirical
Second	A few centuries	Theoretical
Third	A few decades	Computational
Fourth	Today	Data-driven

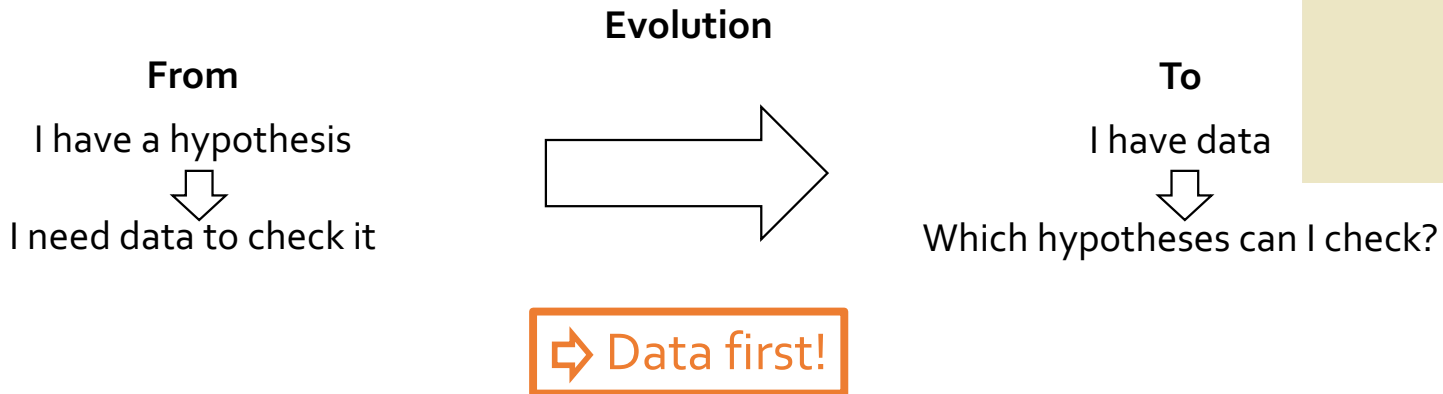

Last but not least....



Resolution 4000 x 3200 px - free download - www.psdgraphics.com

- Cfr:
- Open AI
 - Microsoft
 - Meta
 -

Chat-gpt

- All transformers have the same primary components:
- Tokenizers, which convert text into tokens.
 - A single embedding layer, which converts tokens and positions of the tokens into vector representations.
 - Transformer layers, which carry out repeated transformations on the vector representations, extracting more and more linguistic information. These consist of alternating attention and feedforward layers.
 - (optional) Un-embedding layer, which converts the final vector representations back to a probability distribution over the tokens.

Transformer layers can be one of two types, *encoder* and *decoder*.

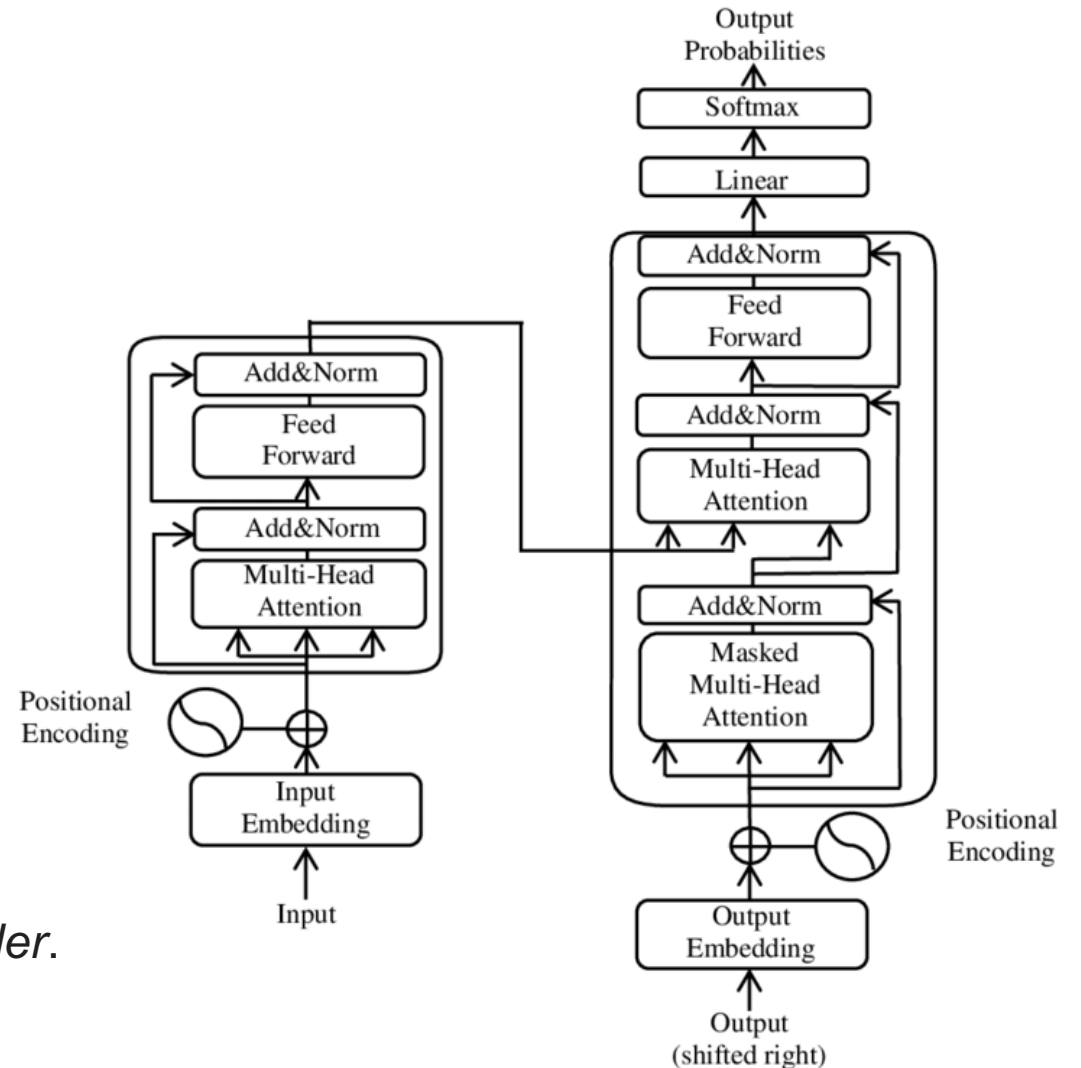

NLP; Trained on MASSIVE amounts of data (books, articles, web,...) or images; +/- 200 BILLION parameters; To be used in: writing, learning, efficiency,...; Problems: bias, ethics, domain knowledge, privacy, language

Hallo liefste familie

Ik wil jullie laten weten dat jullie geen lessen Italiaans meer nodig hebben om vloeiend Italiaans te spreken.

Je kan makkelijk online laten vertalen en je mond wordt automatisch aan jou aangepast.

Dat is erg indrukwekkend.

Ik moet hier een video van dertig seconden opnemen en die duur blijkt verbazingwekkend lang.

Ik ben momenteel pas aan vijftwintig seconden en het blijft maar duren, ik hoop nu de dertig seconden gehaald te hebben.

Tot ziens!



Ciao famiglia più cara

Voglio farvi sapere che non avete più bisogno di lezione d'italiano per parlare fluentemente l'italiano.

Puoi facilmente fare tradurre online e la tua bocca verrà adeguamento adattata a te.

Questo è molto impressionante.

Devo registrare un video qui di trenta secondi e questa durata si rivela sorprendente lunga.

Sono solo a venticinque secondi e continua a durare, spero di superare i trenta ora.

Ciao!

Menu

- AI: what, when, how ?

- Flanders AI Program

- Issues in 'AI in science' policies and science policy for AI

- athumi (Flanders Data Utility Company)





Flanders AI Program: 32 mio €/year



1 RESEARCH (12 mio)



Flanders AI
Research
Program

One Program: critical mass of AI Researchers on a coordinated demand-driven research roadmap

www.flandersairesearch.be

2 IMPLEMENTATION (15 mio)



www.vlaio.be/ai

3 SUPPORTING ACTIVITIES (5 mio)

Skills/Training



Ethics & Legal



Citizen Projects and
Public Outreach



www.vaia.be

data-en-maatschappij.ai/en



Flanders AI Research Program: One Program

KU LEUVEN



Involved in the Program

10 Knowledge Centers
40 Research Groups
90 Professors

150-300-1000-... AI Researchers
Direct funding of 100 PhD
+ 50 other researchers



Flanders AI Research Program

Research Challenge Structure (2024-2028)

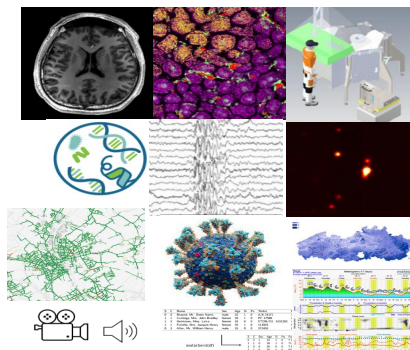

AI-Driven Data Science

Supporting complex **decision making and actionable insights creation** with powerful and intuitive AI-Driven Data Science



Responsible



Resilient and Performant



Sustainable Energy-efficient

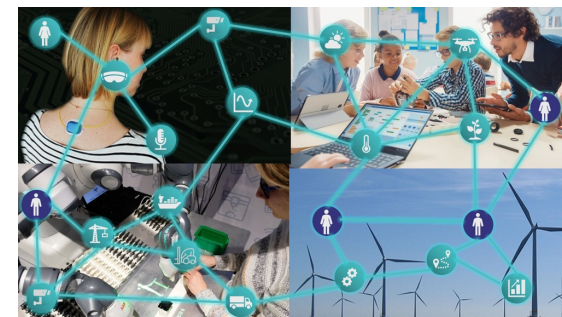

Situated AI

Supporting complex **task execution** in a dynamic environment with (semi-)autonomous AI Systems, collaborating in real time with each other and with people



Human-centered



Productive Data-efficient

AI driven Data Science



Piet Demeester



Bart De Moor

WP1
AI-DRIVEN
DATA
ENGINEERING

Hendrik Blockeel



WP2
SYMBOLIC AND
SUBSYMBOLIC
LEARNING AND
REASONING

Luc De Raedt



WP3
AI ASSISTED
DATA
EXPLORATION

Tijl De Bie



WP4
AUTOMATION
IN MACHINE
LEARNING

Tom Dhaene



WP5
UNDERSTANDING
IMAGES &
AUDIO

Tinne Tuytelaars

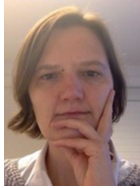

RESPONSIBLE AI
WP6
DECISION SUPPORT SYSTEMS`

Matthew Blaschko Yves Moreau



HEALTH

**PLANET
& ENERGY**

INDUSTRY

SOCIETY

Use cases in four domains



HEALTH



INDUSTRY



PLANET &
ENERGY



SOCIETY

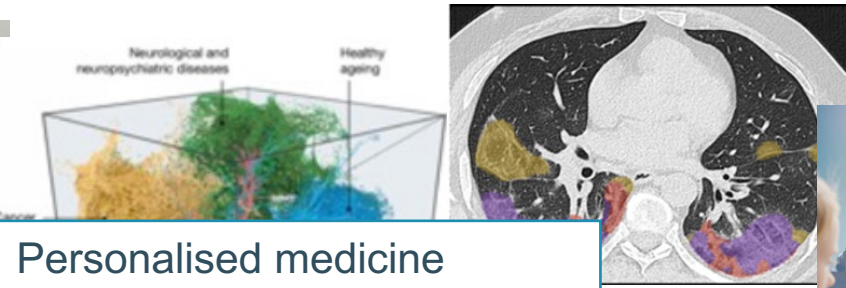

Personalised medicine

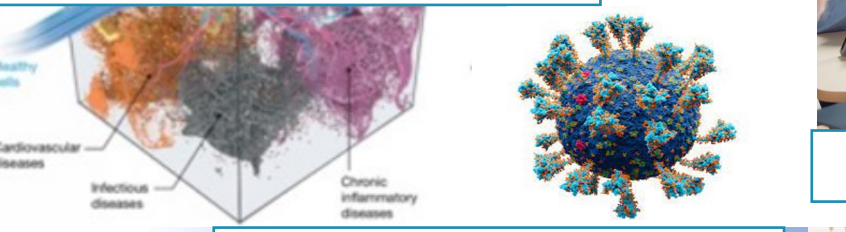

Precision agriculture



Flexibility and improvement of productivity in manufacturing industry



Lifelong learning



Safe & mobile

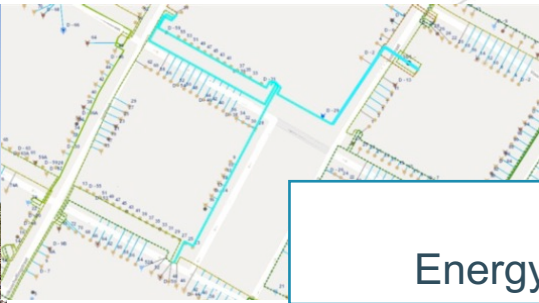

Energy transition
Energy distribution and production

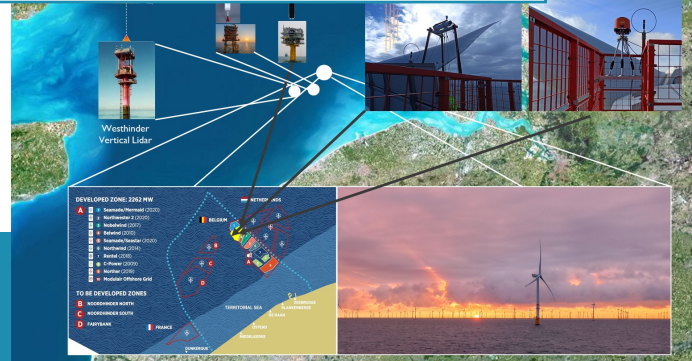

Use Cases

Overview

GC2-WP5



Monitoring@Home

Real-world evidence

Medical Imaging

Single Cell

Digital Twin Cardio

ICU

Personalized Dermatology

Sports

18

WPI

WP2

WP3

WP4

WP5

WP6

Smart Machines

Monitoring&Control of Production&Machine

Production Optimization

Straight-through-digitalization manufacturing

Prognostics and Health Management for Assets

Refurbishment

Natural Environment

Geo Platform-Urban

Smart Grid

Public Employment

Digital Humanities

Education & Training

GC2-WP4

GC2-WP2/3



INDUSTRY

GC2-WP5

GC2-WP4



PLANET & ENERGY

GC2-WP5

GC2-WP3



SOCIETY

DOI:10.1145/3495256

Given the complexity of data science projects and related demand for human expertise, automation has the potential to transform the data science process.

BY TIJL DE BIE, LUC DE RAEDT, JOSÉ HERNÁNDEZ-ORALLO, HOLGER H. HOOS, PADHRAIC SMYTH, AND CHRISTOPHER K.I. WILLIAMS

Automating Data Science

Data Engineering:

data wrangling,
data integration,
data preparation,
data transformation,
...

Model Building:

algorithm selection,
parameter optimization,
performance evaluation,
model selection,
...

Data Exploration:

domain understanding,
goal exploration,
data aggregation,
data visualization,
...

Exploitation:

model interpretation and visualization,
reporting and narratives,
predictions and decisions,
monitoring and maintenance,
...

Generic data processing tasks

- Data preprocessing, denoising, normalization
- Clustering and classification; feature detection; profiling;
- Relevance detection, ranking
- Dynamic modelling, time series, longitudinal modelling
- Decorrelation, modelling, (Kalman) filtering
- Predictive analytics
- Visualization
- Heterogeneous data fusion
- Prediction, processing and monitoring

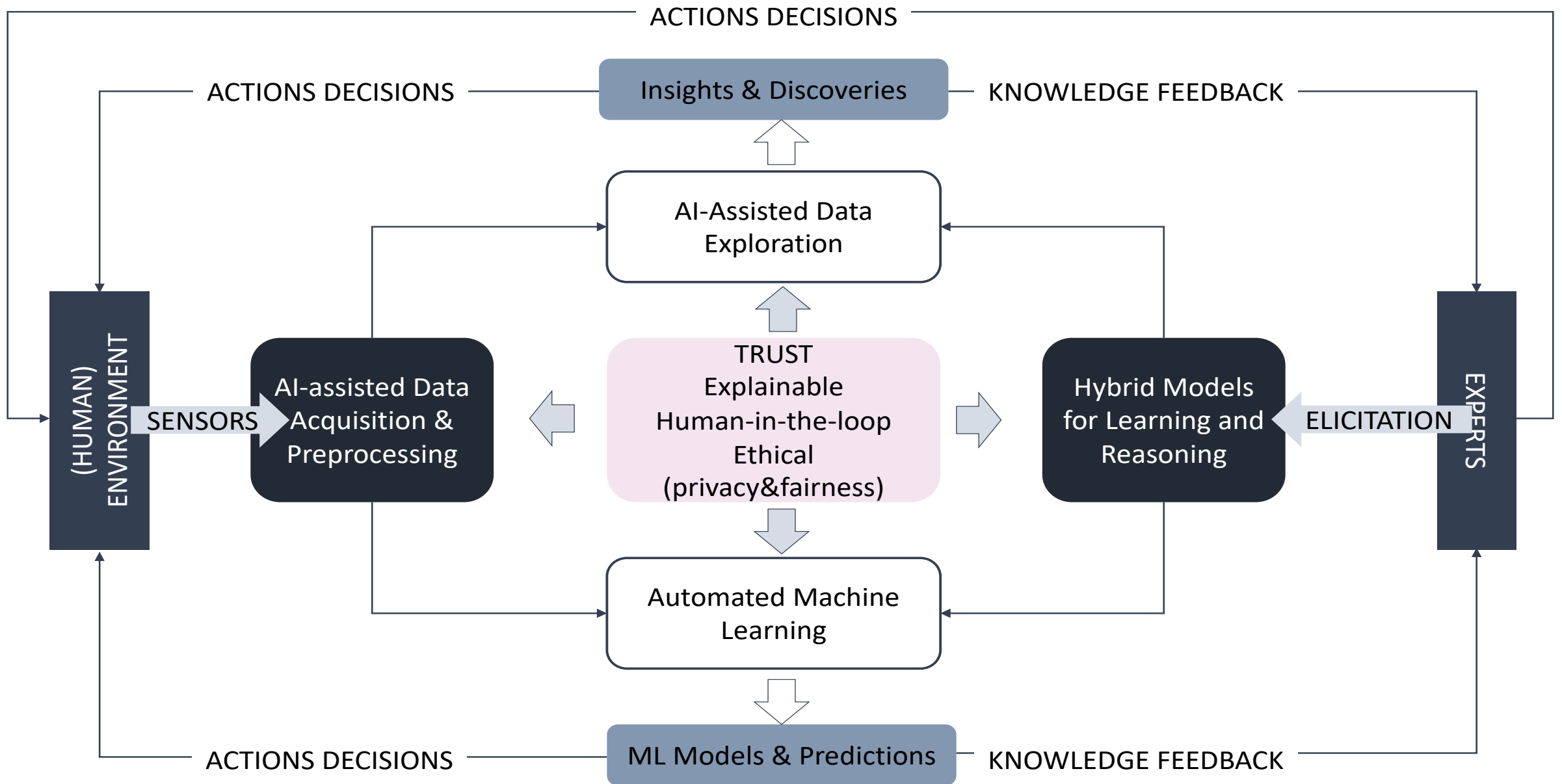

Menu

- AI: what, when, how ?

- Flanders AI Program

- Issues in 'AI in science' policies and science policy for AI

- athumi (Flanders Data Utility Company)



Dr. Algorithm is coming



"In the next 10 years, data science and software will do more for medicine than all the biological sciences together."

– Vinod Khosla, Khosla Ventures

An AI revolution is brewing in medicine

Excitement seems to be growing about generalist medical artificial intelligence (AI). Unlike the tools available now, which serve specific functions such as detecting lung nodules in a chest scan, generalist models would act more like a physician.

They could assess every anomaly in a scan and even create something like a diagnosis. Inspired by the models underlying chatbots such as ChatGPT, they would be trained on massive data sets in the hope that it will give them broad capabilities.

Example: Genomic markers for Leukemia

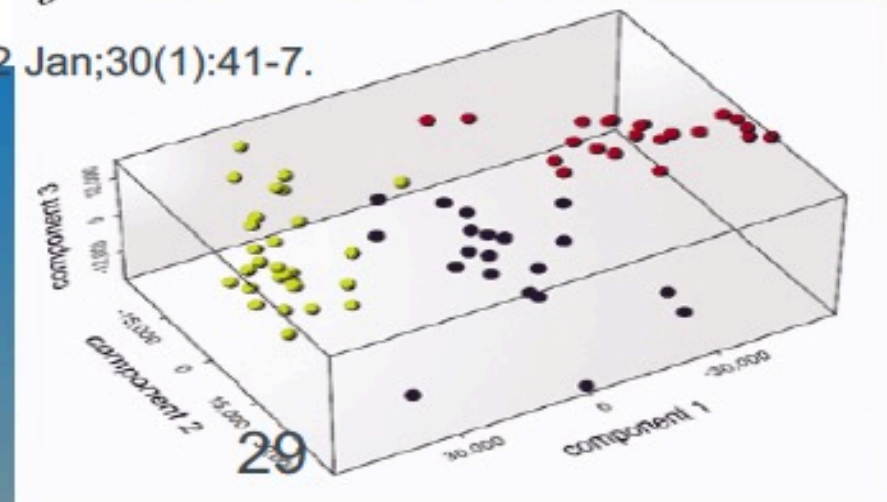
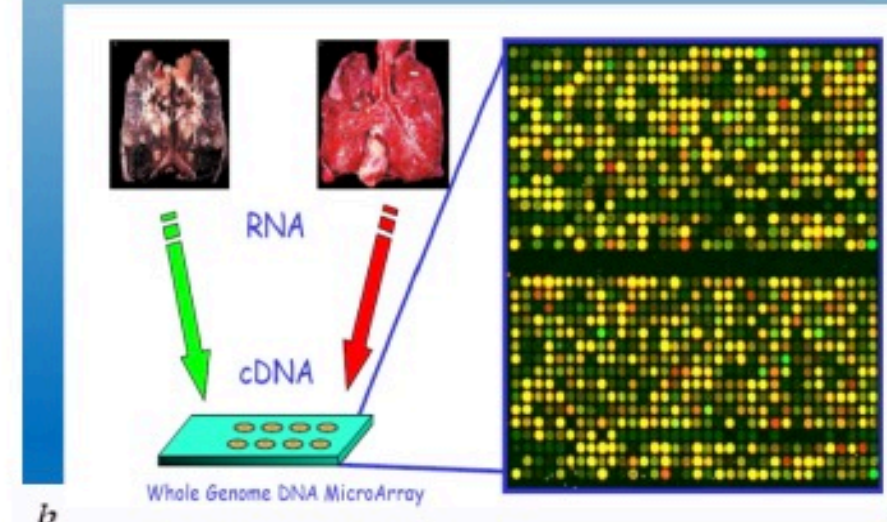
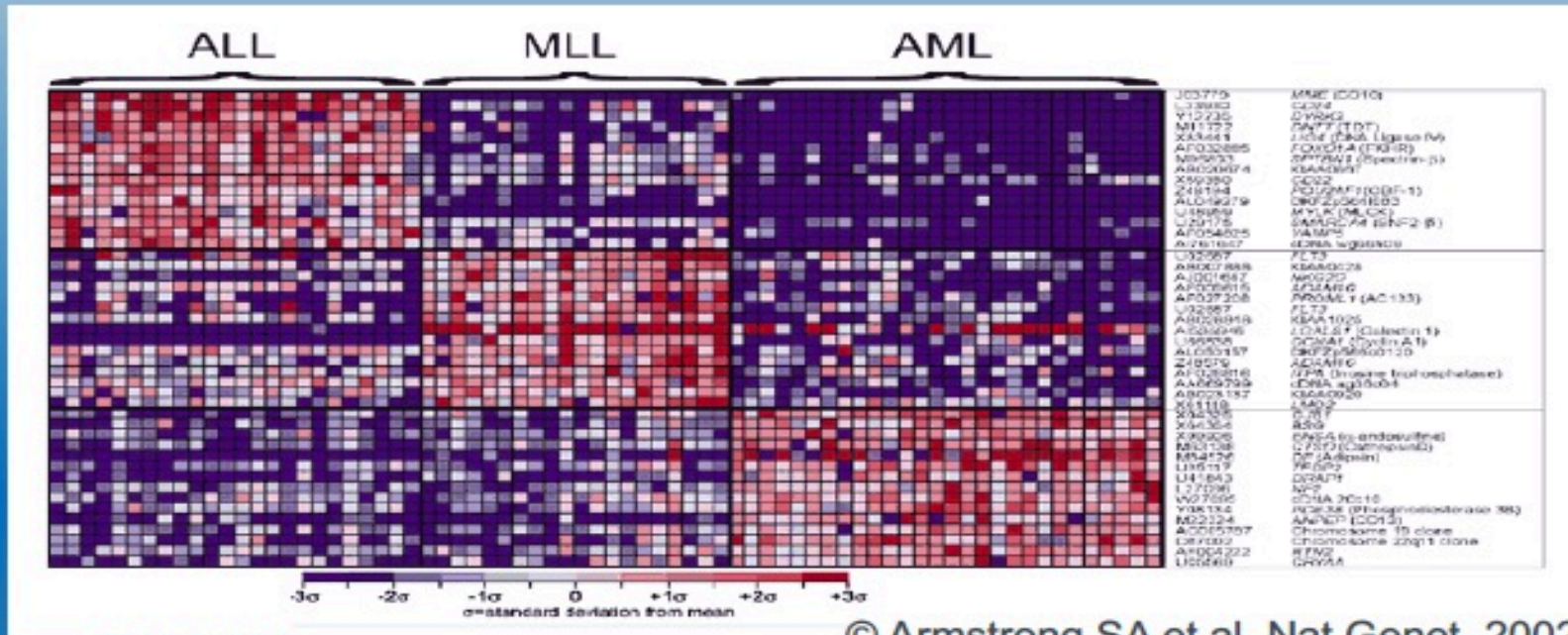

© Armstrong SA et al. Nat Genet. 2002 Jan;30(1):41-7.

12 600 genes

72 patients

- 28 Acute Lymphoblastic Leukemia (ALL)
- 24 Acute Myeloid Leukemia (AML)
- 20 Mixed Linkage Leukemia (MLL)

Digital Twin Cardio

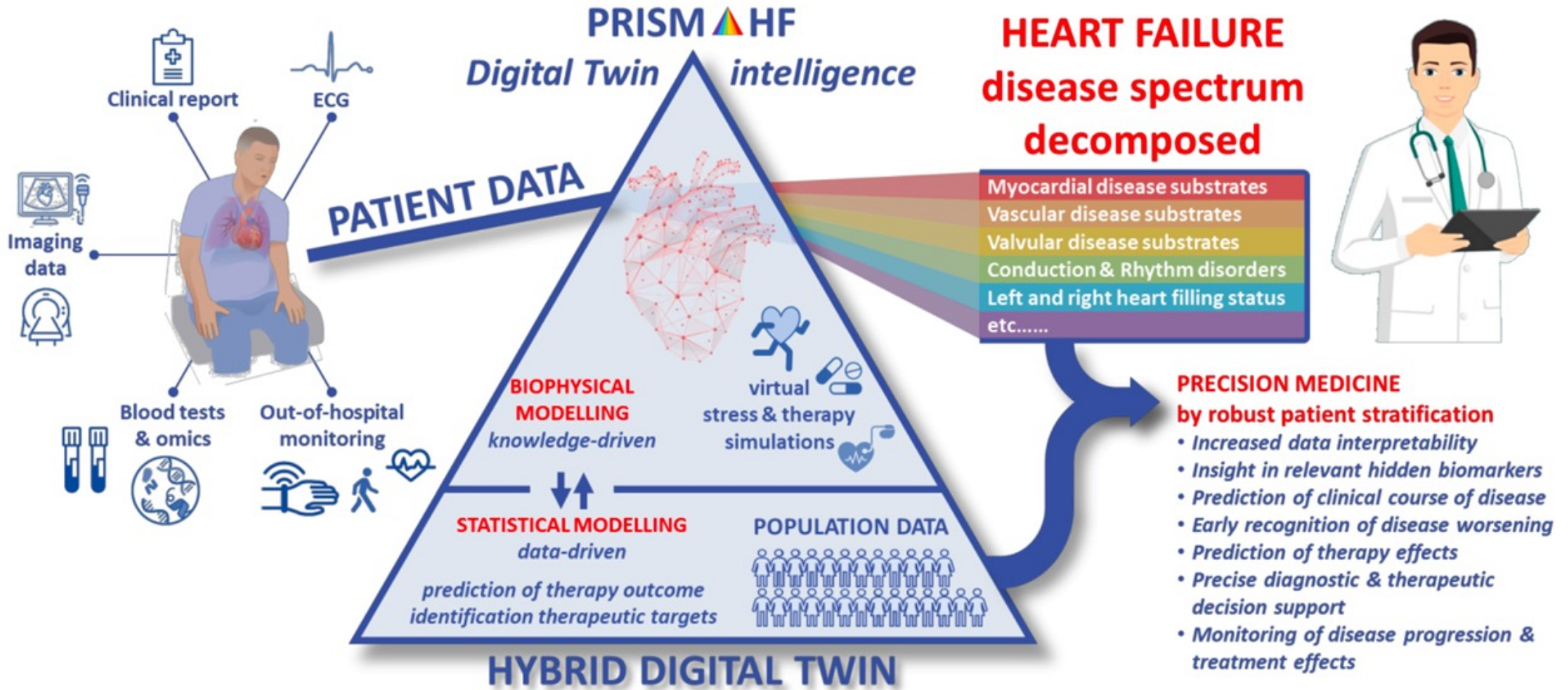

The objective of this use case is to provide disease-tailored treatments for each individual patient at the right time according to their individual pathophysiological disease spectrum by harvesting multimodal and heterogeneous data and allowing to dynamically update those predictions when additional data becomes available.

cDSS for enhanced interpretation of Mass Spectrometry Imaging data using Deep Learning

Deep Learning Enables Spatially-aware Clustering of Ion Images in MSI Data

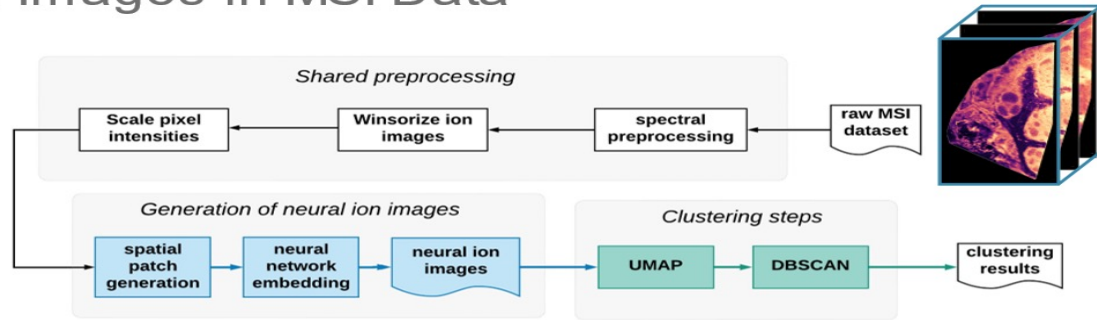

Neuron ion images using pre-trained neural networks enabled direct incorporation of spatial expression patterns, improving clustering of similar ion images, making them readily available as inputs for any downstream machine learning pipeline

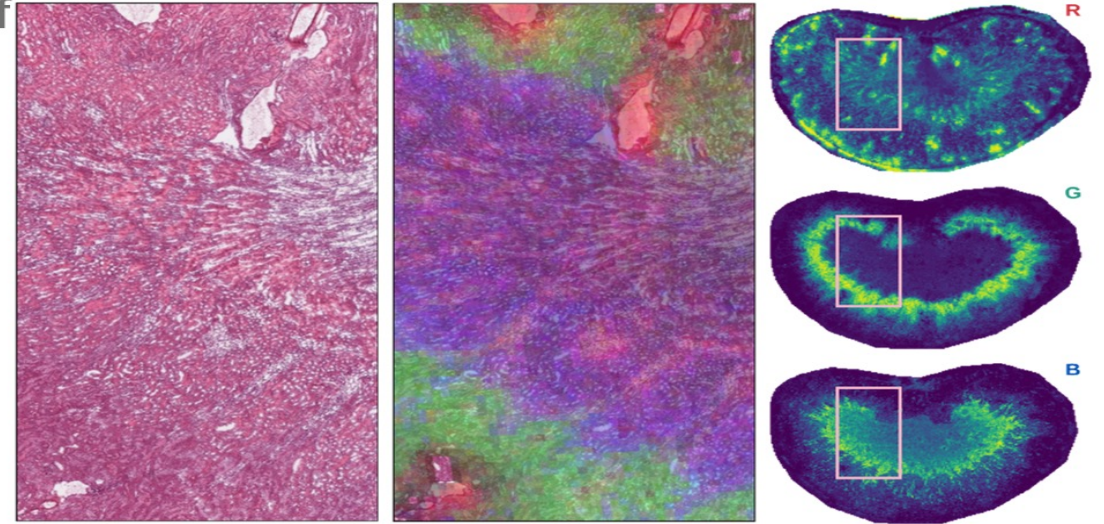

Mass Spectrometry Imaging Data Analysis Using Unsupervised Machine Learning

UMAP, with its very memory efficient GPU implementation, outperforms the other methods in computational time, and gives the most intuitive visualisations on our datasets available.

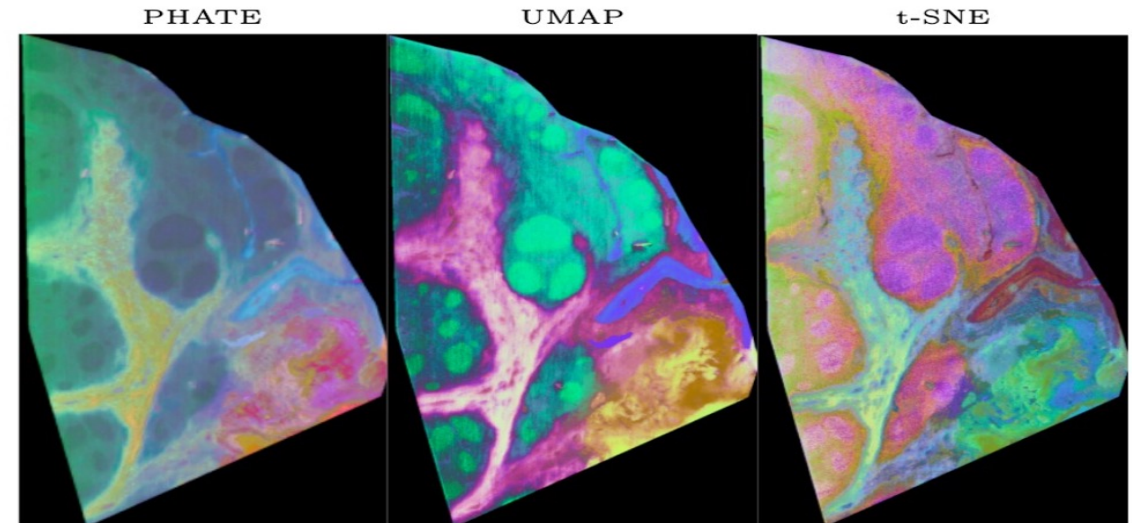
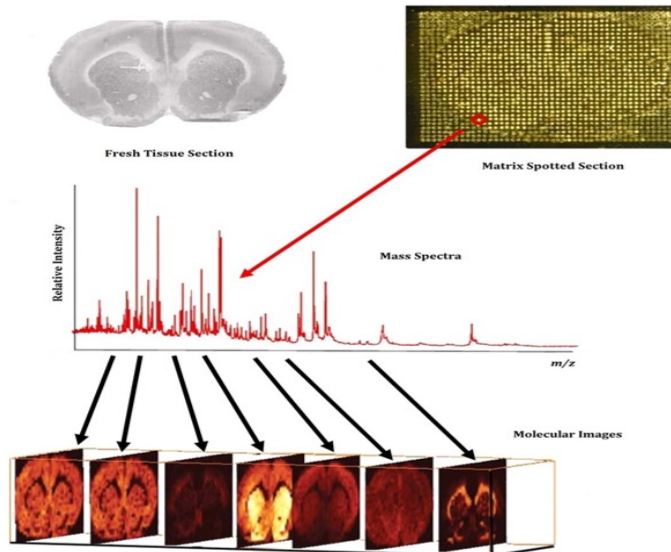

Data-driven derivation and validation of novel phenotypes for acute kidney transplant rejection using semi-supervised clustering

JASN

JOURNAL OF THE AMERICAN SOCIETY OF NEPHROLOGY

BACKGROUND

The Banff classification for kidney transplant histology is increasingly complex with intermediate and mixed rejection phenotypes.

METHODS

Training cohort

Validation cohorts



1 Belgian kidney transplant center
3510 biopsies

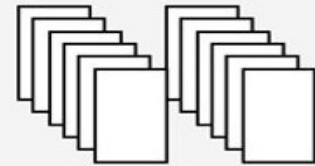

2 French transplant centers with
3835 biopsies

Semi-supervised clustering

Acute Banff lesion scores

+

Graft survival information



RESULTS

Six data-driven histological (rejection) phenotypes that are clinically sound and that associate with graft failure

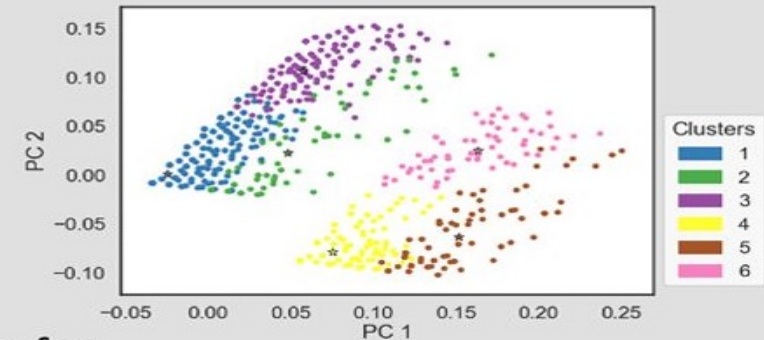

Intuitive visualization algorithm for rejection phenotype + severity

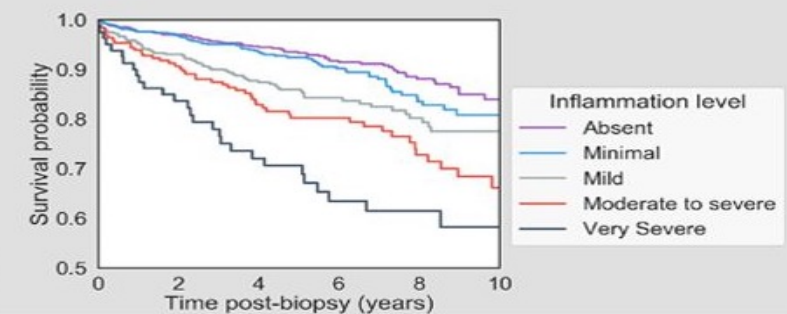
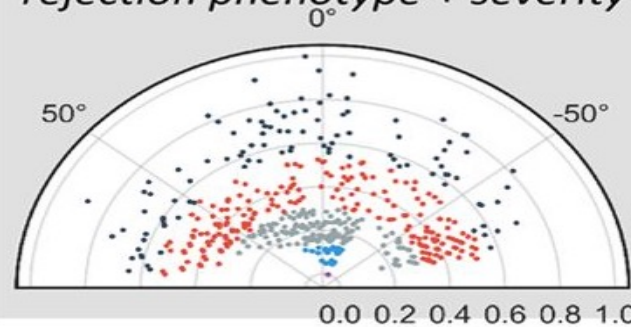

Conclusion

Based on data-driven clustering, six novel clinically and histologically meaningful phenotypes are discovered and validated on external data. Each of them significantly associates with graft failure and overcomes the current limitations of intermediate and mixed Banff phenotypes.

doi: 10.1681/ASN.2020101418

Automate and generalize the development and implementation of AI solutions for Real-World-Evidence generation for several complex clinical finalities

3 clinical finalities



Multiple sclerosis

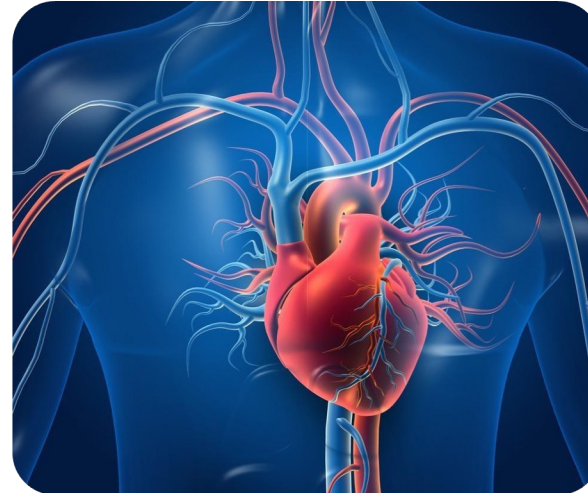

Cardiovascular disorders



Risk pregnancy

- During the recent years, several (isolated) demonstrator projects have shown the potential of the use of AI for improved RWE generation - Technical challenges that are tackled in specific demonstrators are not always use-case specific. It remains unclear how easily lessons learned from one use case can be leveraged to a variety of clinical research questions
- Urgent need to scale and speed-up the development of so called “AI solutions” and reduce recurring costs and increased time to address several clinical research questions

Menu

- AI: what, when, how ?

- Flanders AI Program

- Issues in 'AI in science' policies and science policy for AI

- athumi (Flanders Data Utility Company)



USE CASE EXAMPLE: INDUSTRY 4.0

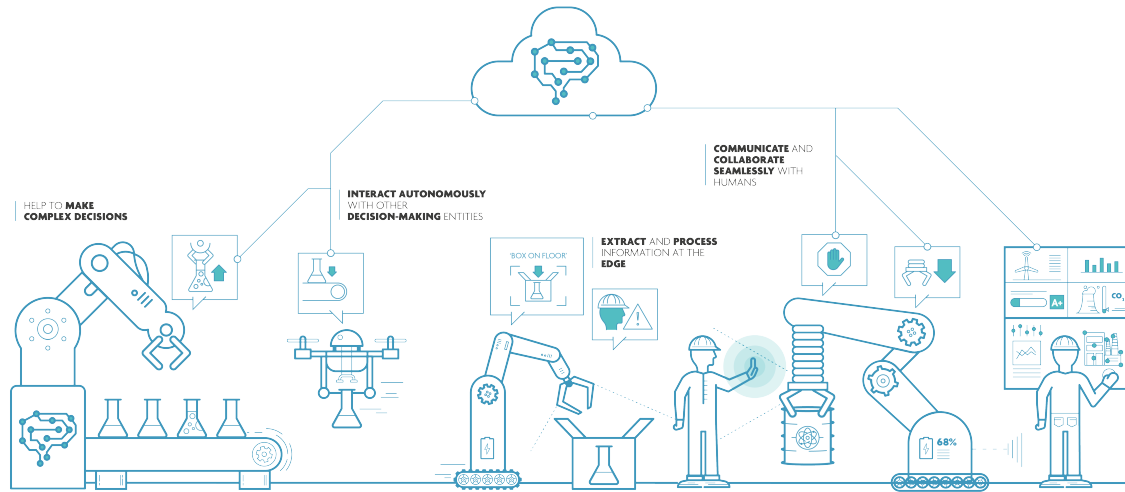

Control of the synthesis section of a Urea plant using MPC control techniques



Urea plant of Yara at Brunsbüttel (Germany)

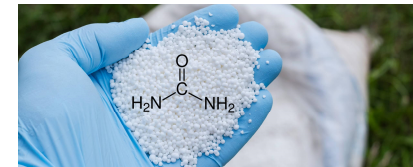

Urea: nitrogenous fertilizer

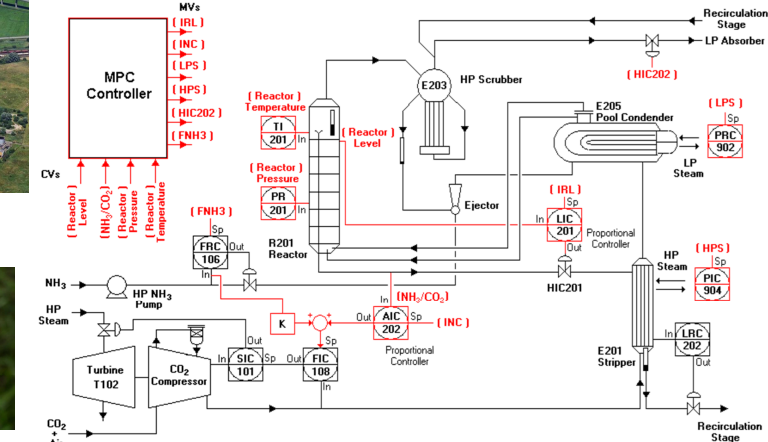

Model Predictive Control (MPC) strategies were used for stabilizing and maximizing the throughput of the synthesis section of a urea plant, while satisfying the process constraints.

Day-ahead consumption forecasting in the Low Voltage (LV) grid using Deep learning

AI FLANDERS
BUILDING OUR DIGITAL FUTURE

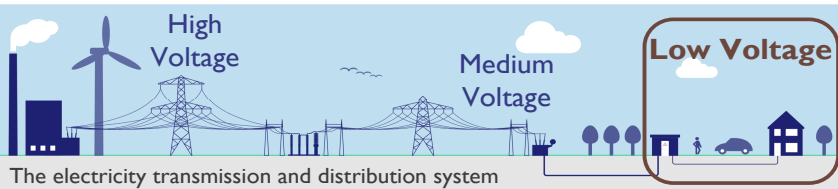

The electricity transmission and distribution system

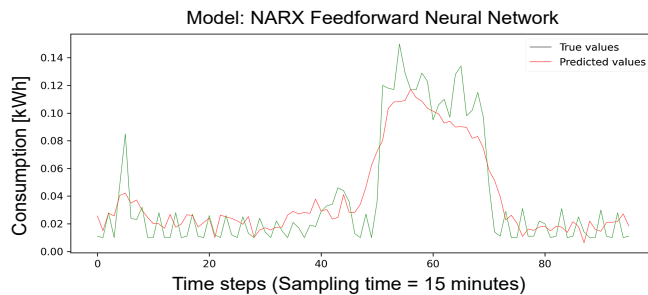

The goal is to build data-driven mathematical models to forecast the electricity consumption of households one day ahead.

Which house is connected to what phase?

Which house is connected to what cable?

How to optimize the grid layout with minimal operator actions?

How do heat pumps and electrical cars behave?

Where are the open points?

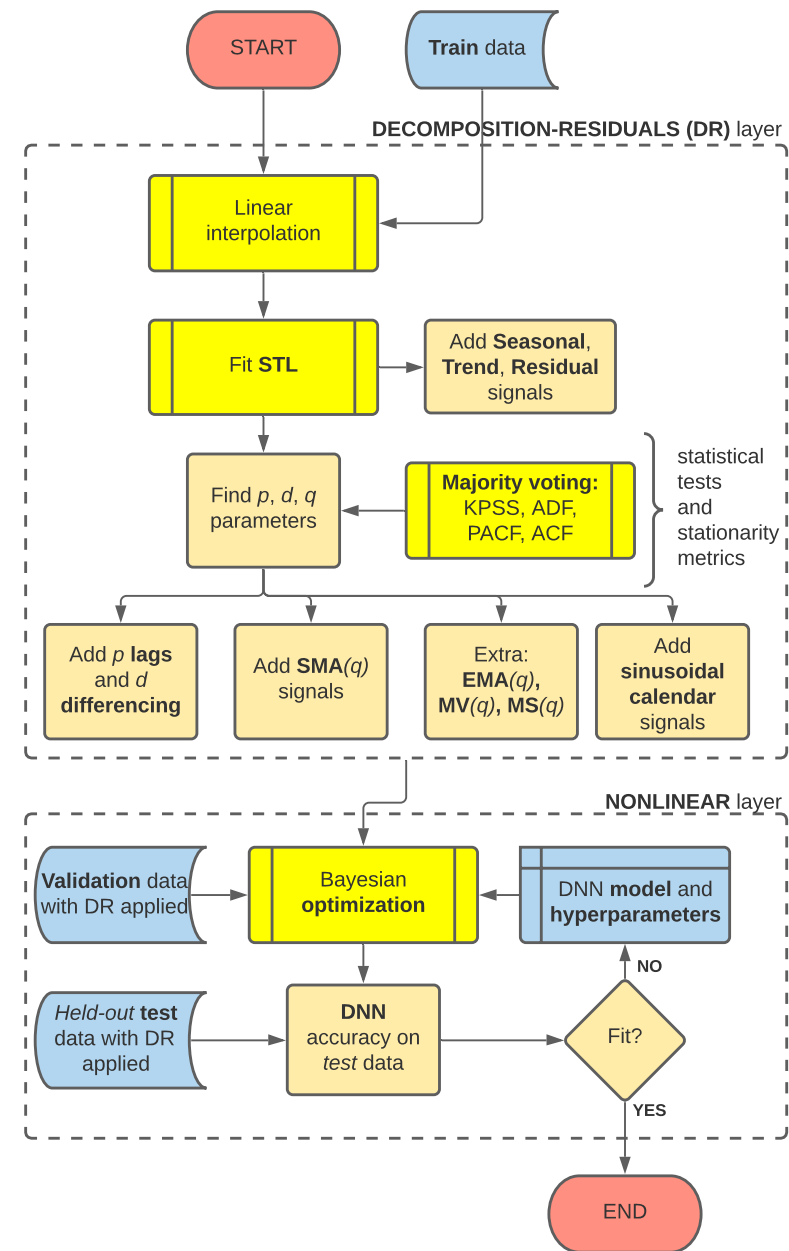
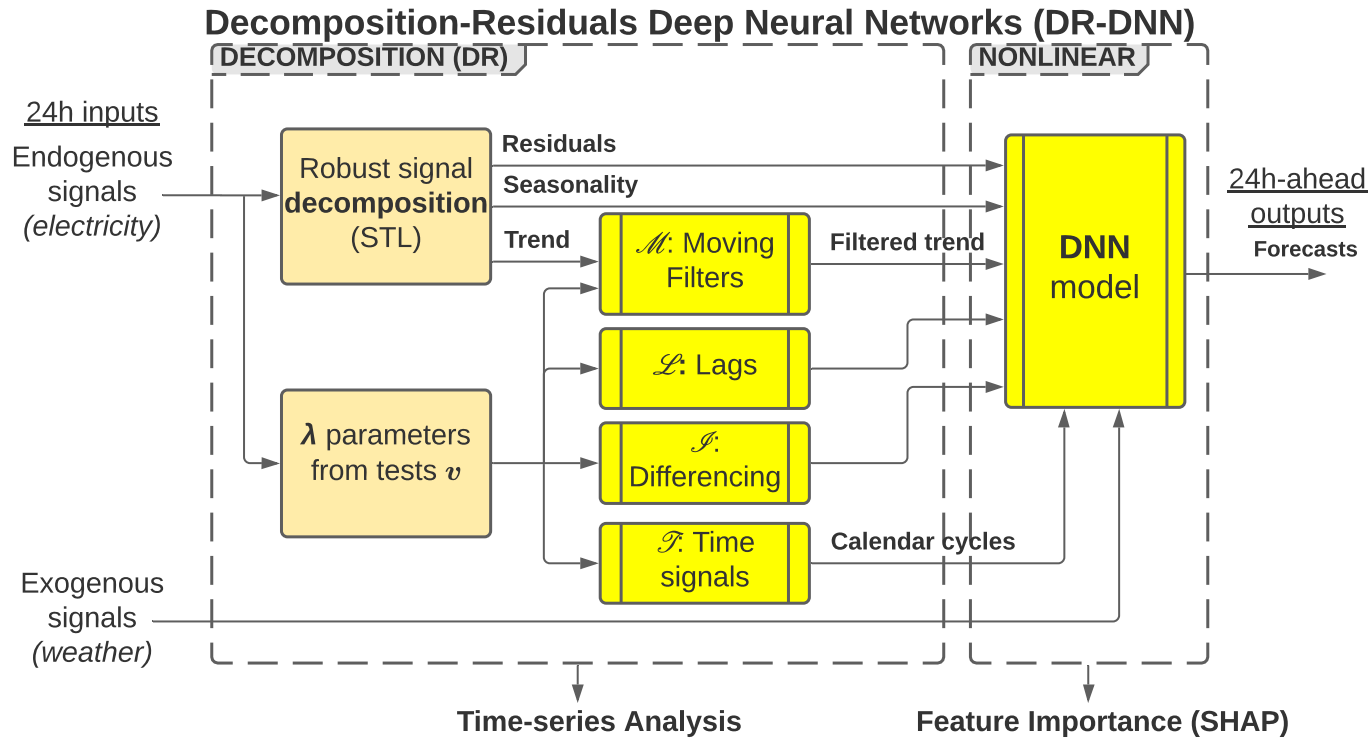

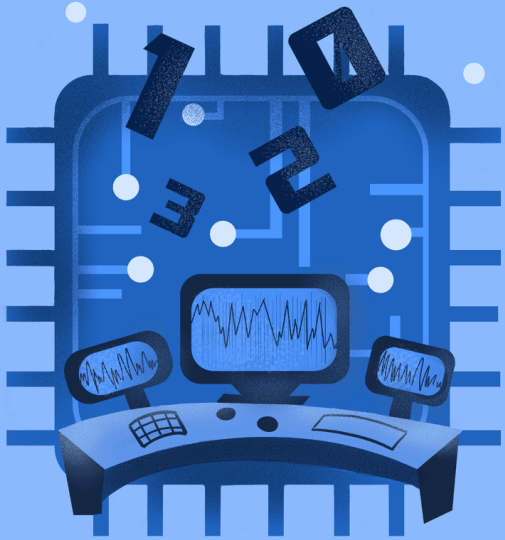

High-Frequency Trading (HFT)

[ˈhɪ ˈfr̩ːkwən(t)-sē ˈtrā-dɪŋ]

Using powerful computer programs to transact a large number of orders in fractions of a second.

 Investopedia

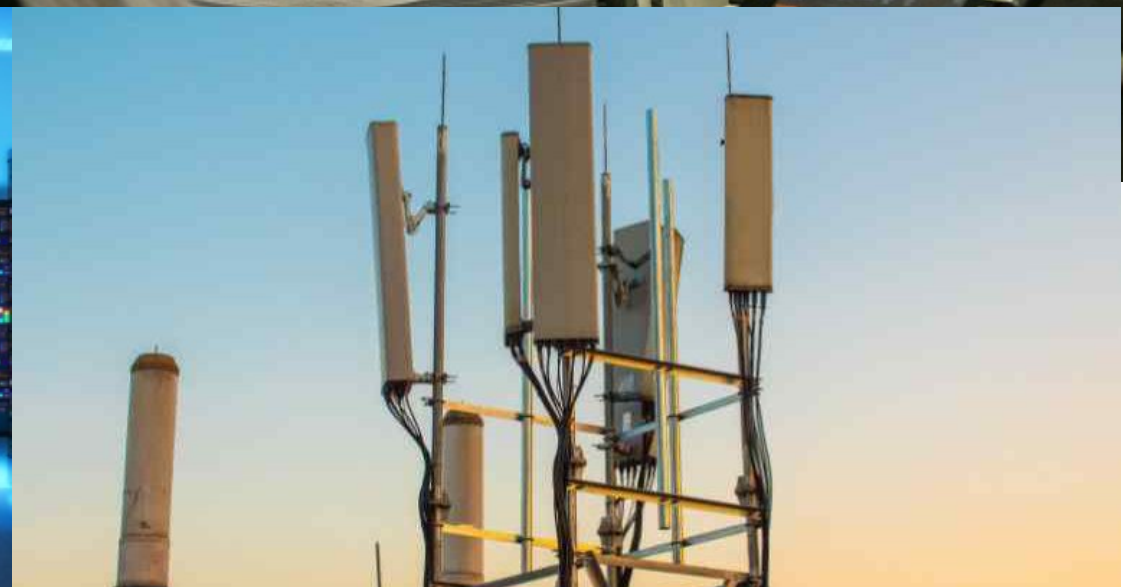

Menu

- AI: what, when, how ?
- Flanders AI Program
- Issues in 'AI in science' policies and science policy for AI
- athumi (Flanders Data Utility Company)



AI in and for urban and geographical research

Heterogeneous data



Human expertise



Scalability

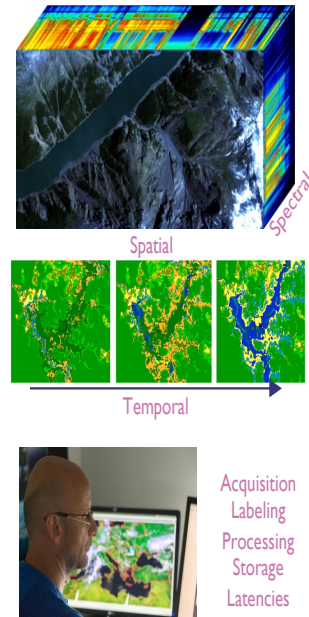

Uncertainty

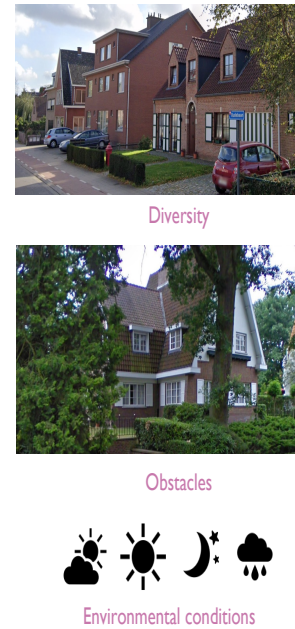

- Data transformations for heterogeneous data
- Integrated information extraction from imagery, databases, graphs, ...
- Multimodal data exploration and modeling

- Dealing with limited ground truth
- Incorporate spatial structure cues
- Expert knowledge-based learning
- Explainable to human experts

- Dense representation learning
- Unsupervised learning at object level
- Efficient data acquisition strategies
- 3D shape/volume extraction

- Uncertainty aware decision making
- Scene decomposition
- Continual learning
- Domain shifts

GROWING AI USE IN EARTH AND SPACE SCIENCE

A rising proportion of abstracts for the annual meeting of the American Geophysical Union mention artificial intelligence (AI) or machine learning (ML) — a trend seen across all areas of geoscience.

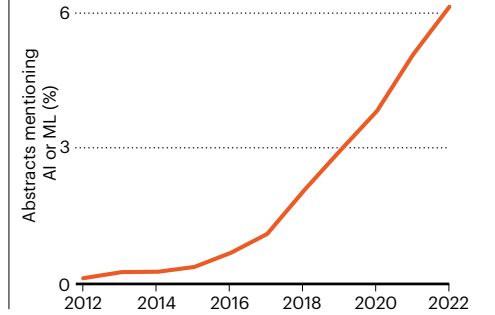

Data assimilation in the Air-quality model Aurora

O₃ air-quality stations

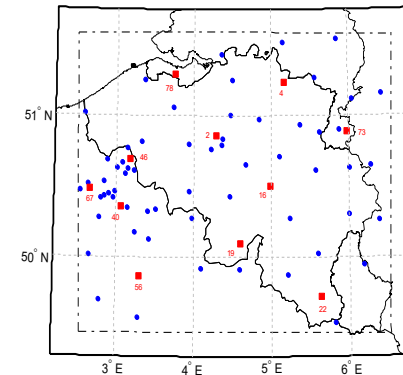

Average of the O₃ concentration over the validation stations

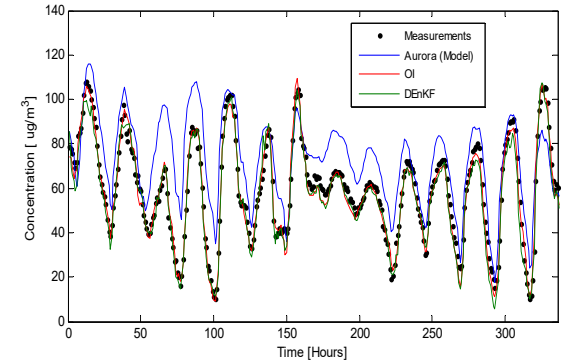

Starting date: May 28th, 2005 at midnight

The objective was to improve the concentration estimates of the air-quality model Aurora by using data assimilation techniques such as Optimal Interpolation (OI), and the Deterministic Ensemble Kalman Filter (DEnKF).

Implementation of a Nonlinear Model Predictive controller (NMPC) for the Demer

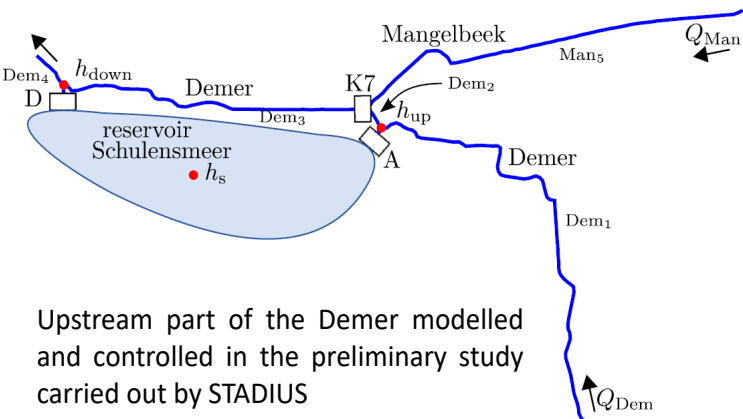

The Demer in Hasselt

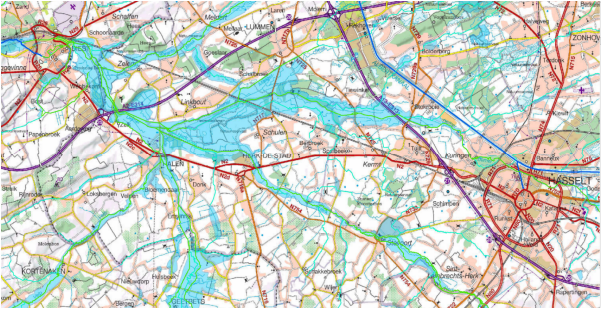

Flooded area during the flood event of 1998
Financial Damage: **> 16 million euro!**

The control goal was to avoid future floodings of the Demer river in Belgium by using NMPC

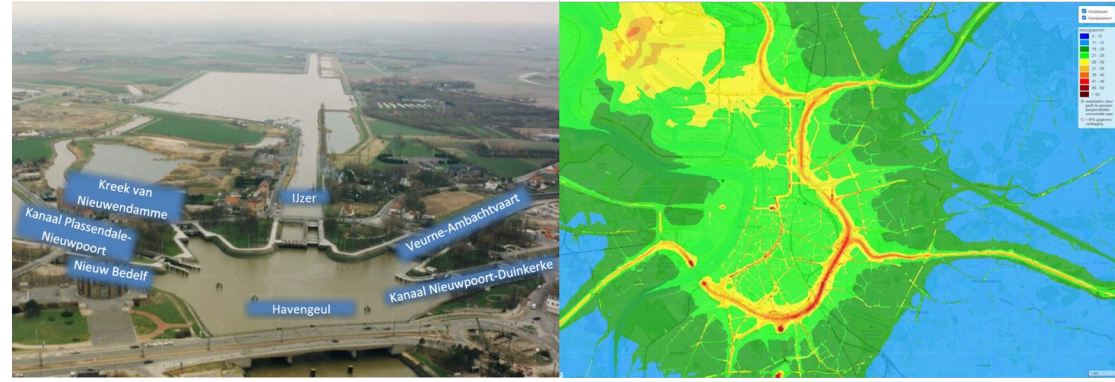

AI helps to save endangered species (Nature)

- Artificial intelligence (AI) can help to fight biodiversity loss by analysing rainforest soundscapes or sifting through tens of thousands of camera-trap images. A neural network that can pick out bird species from audio recordings could be crucial for forest-restoration projects that must demonstrate success to secure continued funding. And an AI that analyses footage in real time has already caught a pangolin poacher in the act. Although scientists should be aware that AI is imperfect and has its own environmental impacts, it's “clearly the way to go”, says Nicolas Mialhe, founder of an AI-governance non-profit.

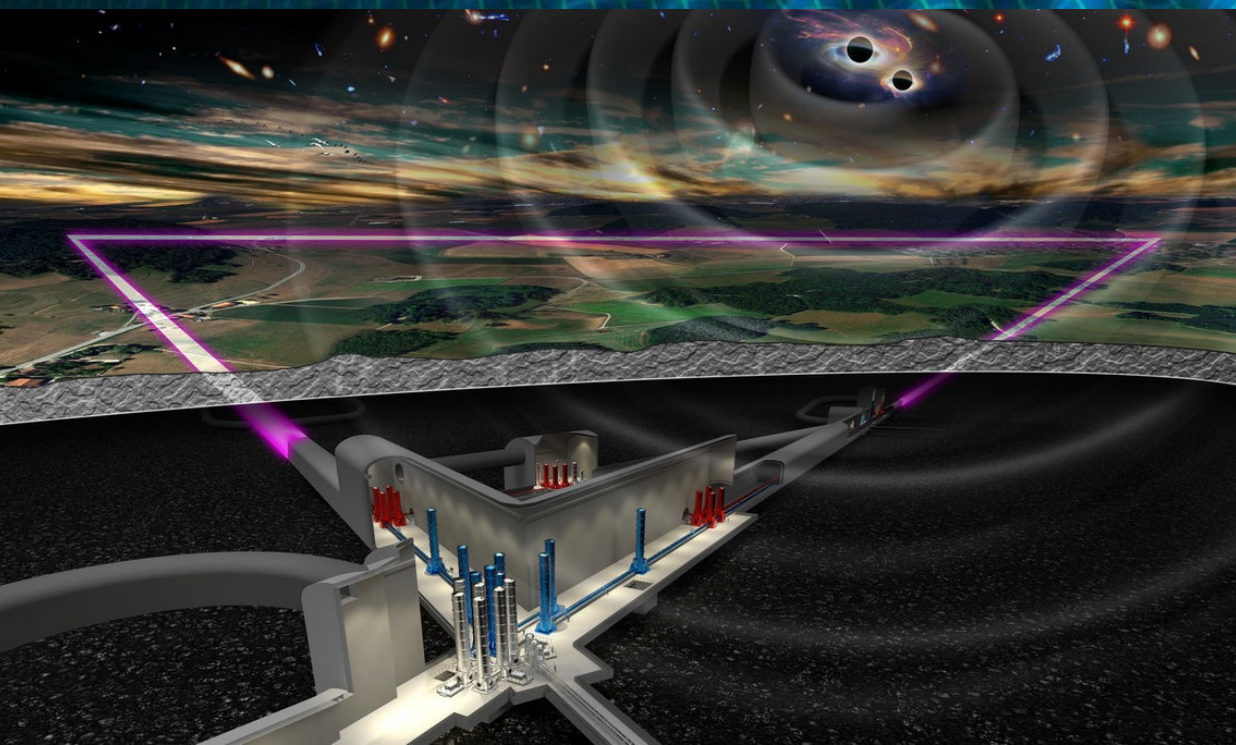

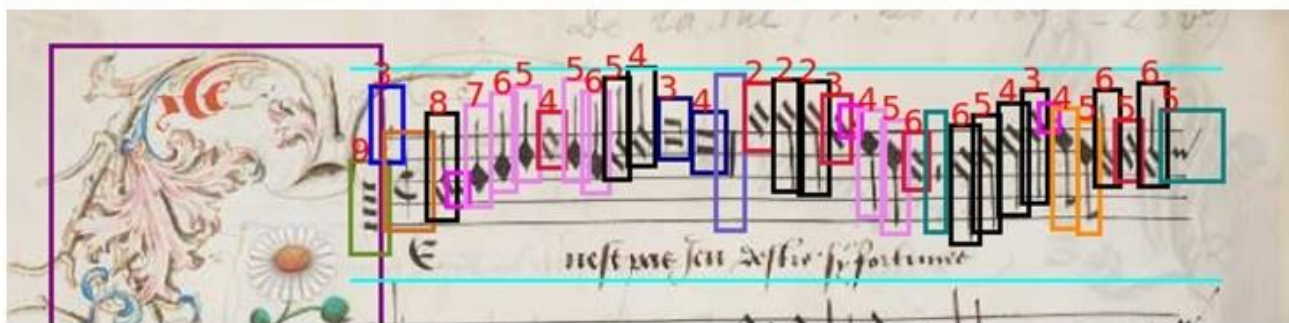

Spin-Off Companies (personal track record)



Specialized in modelling and control of multivariable industrial processes (chemical and power plants, oil exploration) automation & optimization (1995)
<http://www.ipcos.com/en>



Payment fraud detection (2000)
(in 2004 acquired by Norkom Technologies ;
in 2011 Norkom Techn. was acquired by
Detica NetReveal , Bus. Division of BAE
Systems Detica.
<http://www.deticanetreveal.com/en/about-us.html>



Transport & Mobility research & mgt
(2002)
<http://www.tmleuven.be/>



Data mining software & services
for process industry
(2008) <http://www.dsquare.be/>
(won in 2009 the award of "best
spin-off of the year")



TrendMiner: Formerly Dsquare, is the
Belgian big-data in process industry
company that has been acquired by
Software AG
<http://www.trendminer.com/>



Timeseer: Industrial process monitoring
<https://www.timeseer.ai/> 1



In silico drug
discovery (2005)



patient tele-monitoring



Acquired by Agilent
Data handling & mining for clinical genetics
(2008)
<https://www.agilent.com/>



UgenTec delivers an independent diagnostic
software platform to help molecular labs
with their DNA (PCR) analyses. It offers The
FastFinder 2.0 analysis software for helping
lab technicians in their analysis of PCR data.
It serves biotech companies, labs, and IT
companies.
<https://www.ugentec.com/>



Aspect Analytics

Software for mass spectrometry imaging
<https://www.aspect-analytics.com>

Successful high-tech spinoff = TTT = Technology, Team, Traction

Menu

- AI: what, when, how ?
- Flanders AI Program
- Issues in 'AI in science' policies and science policy for AI
- athumi (Flanders Data Utility Company)





Foto: KU Leuven

AI in support of living a healthier life for longer

AI in support of a human-centered prosperous digital future for society

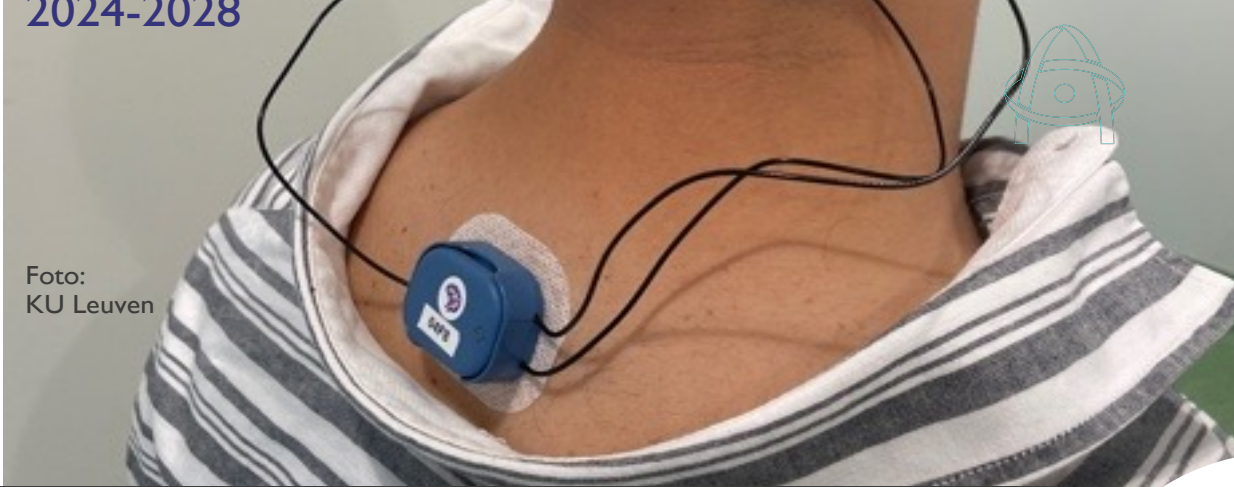

Foto: Flanders Make

AI in support of Industry 5.0: sustainable, resilient, and human-centered

Foto: VUB

AI for sustainability, AI taking care of our planet and supporting the energy transition

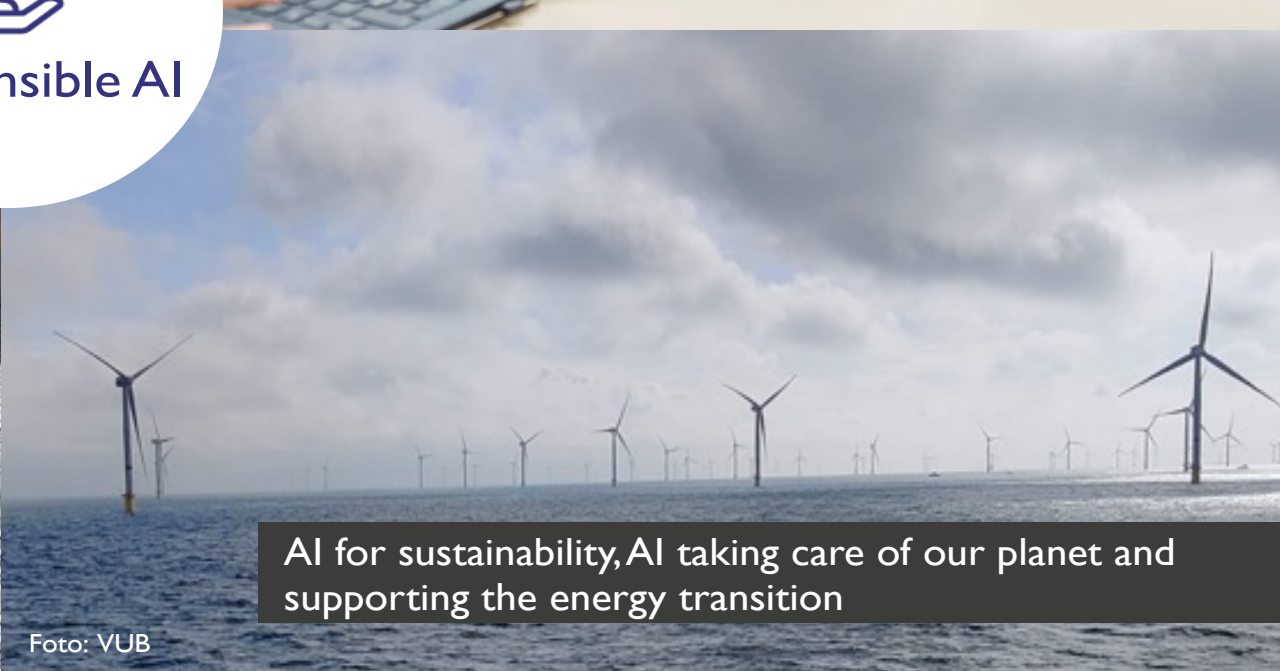
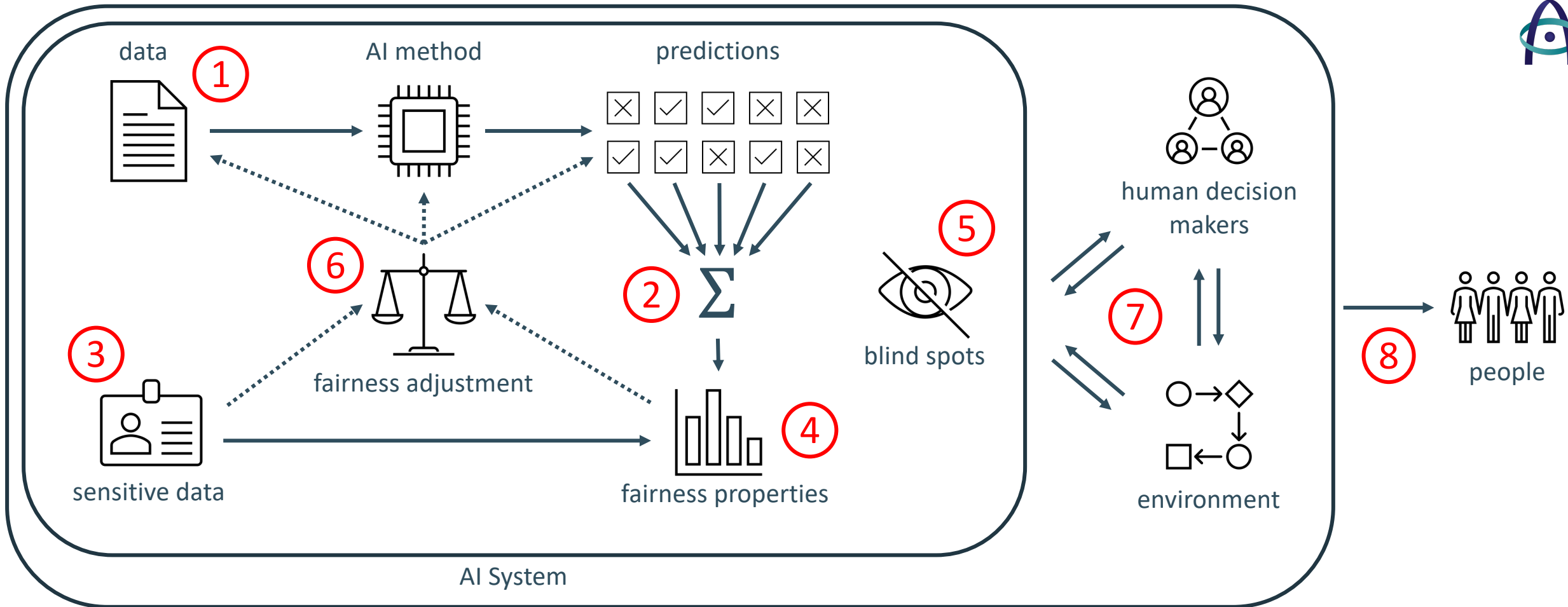

decision process

- ① Lack of Ground Truth
- ② Categorization of Groups
- ③ Need for Sensitive Data
- ④ No Universal Fairness Definition
- ⑤ Blind Spots
- ⑥ Lack of Portability
- ⑦ Limited Power over Full Decision Process
- ⑧ Open to Abuse

Garbage in, garbage out: mitigating risks and maximizing benefits of AI in research

Six principles to help build trust

Following these best practices will help to avert harm when using AI in research.

Researchers

1. Transparency. Clearly document and report participants, data sets, models, bias and uncertainties.
2. Intentionality. Ensure that the AI model and its implementations are explained, replicable and reusable.
3. Risk. Consider and manage the possible risks and biases that data sets and algorithms are susceptible to, and how they might affect the outcomes or have unintended consequences.
4. Participatory methods. Ensure inclusive research design, engage with communities at risk and include domain expertise.

Scholarly organizations (including research institutions, publishers, societies and funders)

5. Outreach, training, and leading practices. Provide for all roles and career stages.
6. Sustained effort. Implement, review and advance these guidelines.

Can AI systems learn/ be taught to make ethical choices ?

Can AI systems be taught to deal with differing opinions ?

Einstein Foundation Award 2023 — The Einstein Foundation Berlin awards €500,000 prize to enhance quality in research

The Einstein Foundation Berlin is to honor Belgian bioinformatician Yves Moreau, the Berkeley Initiative for Transparency in the Social Sciences, and the Responsible Research Assessment Initiative with this year's Einstein Foundation Award for Promoting Quality in Research 2023.

The recipient of the **Individual Award** is Yves Moreau from the Katholieke Universiteit Leuven. Moreau ranks among the most ardent advocates for ethical standards in the utilization of human DNA data in the age of artificial intelligence and big data. He designs algorithms that protect personal privacy during the analysis of genetic data.



AI & Science Policy

In June OECD published [a report on applying AI to accelerate productivity in research](#), in which it says, “While AI is penetrating all domains and stages of science, its full potential is far from realised. Policy makers and actors across research systems can do much to accelerate and deepen the uptake of AI in science, magnifying its positive contributions to research.”

National Institutes of Health (NIH) in the US has placed limits on generative AI in its peer review processes

US national Science Foundation has put together an internal working group to find out if there are ways to integrate AI tools in the production of science

A recent workshop at the National Academies explored the present and future of artificial intelligence in advancing discovery across a range of scientific fields, from physics to neurology to meteorology.

While the EU is in the process of finalising its first regulation on artificial intelligence, the scientific community is yet to come up with a unified response on how generative AI could be used in higher education and research

European Commission (new unit E4: Industry 5.0 and AI in Science): To develop new policy on how to use AI to improve scientific productivity and avoid misuse, copyright and academic dishonesty (“CHATGPT detector catches AI-generated papers with unprecedented accuracy”).

EU Commission (policy brief preview)

1. Introduction

2. Context

(History of AI, European approach to AI)

3. Why the EU needs a policy for AI in Science

- 3.1 Global competition is under way to harness AI's potential in science
- 3.2 The EU needs a competitive advantage in the global AI race
- 3.3 AI-boosted science can deliver growth and solutions to societal challenges
- 3.4 AI in science comes with new challenges, risks and ethical considerations

4. What AI can do for Science

- 4.1. AI in Science: a tool for accelerated discovery
- 4. 2. AI helping science solve global challenges
- 4. 3. AI-driven collaboration: unlocking innovation

5. A Glimpse into the Future: AI from toolbox to “brainbox”

6. What new challenges from AI in Science

- 6.1 AI amplifies ethical issues in science
- 6.2 The problem of public trust in AI-driven research
- 6.3. Talent and education system challenges
- 6.4 Challenges related to data, resources and infrastructures
- 6.5. Regional disparities and the integration of AI in Science

7. Solutions to enable uptake of AI in Science

- 7.1 Vision and governance for AI in Science
- 7.2. Anticipate impact and preserve trust in the scientific practice
- 7.3 Ramping up access to data, assets and compute infrastructures
- 7.4 EU R&I funding for AI-driven science
- 7.5 Enhancing capacities for AI-driven interdisciplinary research
- 7.6 Education and skills, access to talent

8. Conclusions

Annex I: EU initiatives supporting AI in Science

President Biden Issues Executive Order on Safe, Secure, and Trustworthy AI

- Require that developers of the most powerful AI systems share their safety test results and other critical information with the U.S. government.
- Develop standards, tools, and tests to help ensure that AI systems are safe, secure, and trustworthy.
- Protect against the risks of using AI to engineer dangerous biological materials
- Protect Americans from AI-enabled fraud and deception by establishing standards and best practices for detecting AI-generated content and authenticating official content.
- Establish an advanced cybersecurity program to develop AI tools to find and fix vulnerabilities in critical software,
- Order the development of a National Security Memorandum that directs further actions on AI and security.
- Protect Americans' privacy by prioritizing support for accelerating the development and use of privacy-preserving techniques
- Strengthen privacy-preserving research and technologies,
- Evaluate how agencies collect and use commercially available information
- Develop guidelines for federal agencies to evaluate the effectiveness of privacy-preserving techniques,
- Provide clear guidance to landlords, Federal benefits programs, and federal contractors
- Address algorithmic discrimination
- Ensure fairness throughout the criminal justice system
- Advance the responsible use of AI in healthcare and the development of affordable and life-saving drugs.
- Shape AI's potential to transform education
- Develop principles and best practices to mitigate the harms and maximize the benefits of AI for workers
- Produce a report on AI's potential labor-market impacts,

President Biden Issues Executive Order on Safe, Secure, and Trustworthy AI

- Catalyze AI research across the United States
- Promote a fair, open, and competitive AI ecosystem
- Use existing authorities to expand the ability of highly skilled immigrants and nonimmigrants with expertise in critical areas to study, stay, and work in the United States
- Expand bilateral, multilateral, and multistakeholder engagements to collaborate on AI.
- Accelerate development and implementation of vital AI standards
- Promote the safe, responsible, and rights-affirming development and deployment of AI abroad to solve global challenges
- Issue guidance for agencies' use of AI
- Help agencies acquire specified AI products and services
- Accelerate the rapid hiring of AI professionals

**The US innovates
China imitates
Europe regulates**

True ???

**Europe deals with values
US deals with value creation**

True ???



 **AI SAFETY
SUMMIT**

HOSTED BY THE UK
1-2 NOVEMBER 2023



LUÍS PUIGDEMONT Catalonia	UNITED STATES OF AMERICA	IAN HOGARTH FRONTIER AI TASKFORCE	UNITED KINGDOM	YOSHUA BENGIO MILA-QUEBEC ARTIFICIAL INTELLIGENCE INSTITUTE	EUROPEAN COMMISSION	DR ALO... INSTITUTE
------------------------------	--------------------------	--------------------------------------	----------------	--	---------------------	------------------------

To open or not to open the sources of AI ?

AI risk assessment related to technology security and technology leakage

Guidelines and questionnaire for reporting on findings

The Commission **Recommendation C(2023) 6689 of 3 October 2023** on critical technology areas for the EU's economic security for further risk assessment with Member States (hereafter 'the Recommendation') proposes that Member States, together with the Commission, perform a **risk assessment**, by the end of 2023, related to technology security and technology leakage risks on the artificial intelligence, high-performance computing, cloud and edge computing technology areas.

Dual use ??

Menu

- AI: what, when, how ?
- Flanders AI Program
- Issues in 'AI in science' policies and science policy for AI
- athumi (Flanders Data Utility Company)



Bottlenecks



Technological cost



Lack of standardisation



Lack of confidence

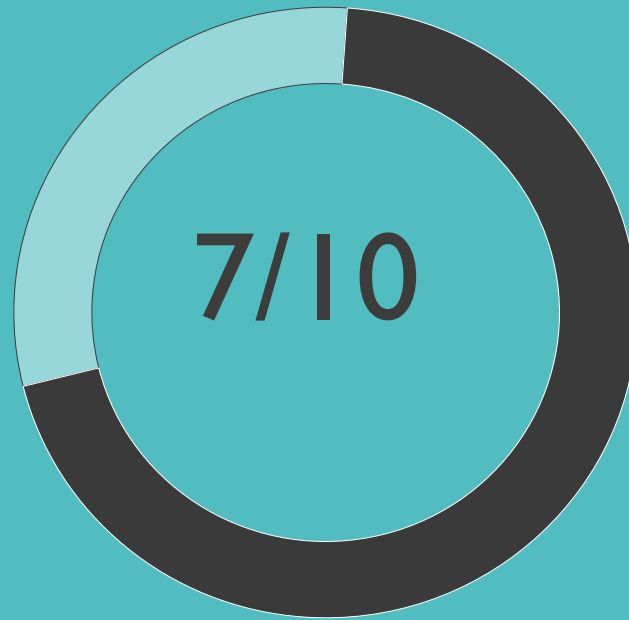

citizens
do not trust
companies
with their data

Source:  SolidLab Digimeter

“We need a midway **course correction** for the Web.”

Sir Tim Berners-Lee

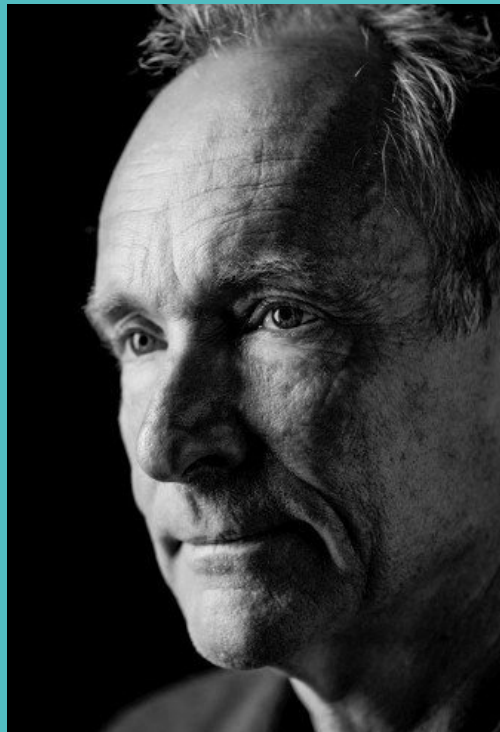

Making **more** data
more usable
for **more** companies



Why the Data Utility Company?

Creating the **Data Utility company** allows companies to make **more data more usable**. This process includes traditional corporate data, as well as confidential data and personal data.

The Data Utility Company thus opens up new opportunities for sectors and companies to collaborate **B2B** and develop innovative B2C services wherein citizens can securely participate without **relinquishing** control of their data.

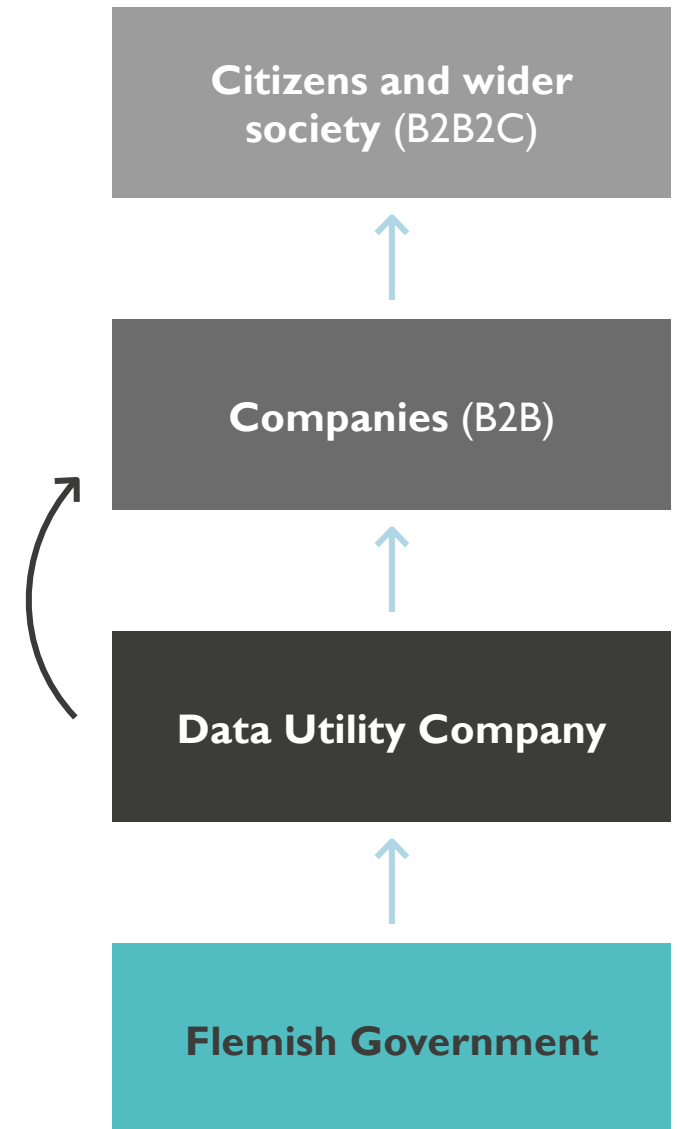

Power of personal data spaces (some examples)

Manage My Career

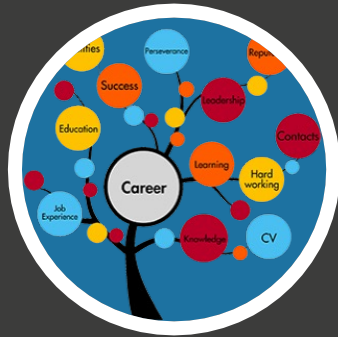

How can I make better career decisions using my data?

Manage My Home



How can I better organise my house & home based on my data?

Manage My Health



Thanks to my data, how can I live healthier and get less sick?

Power of Data Collaboration Platforms (some examples)

Cables and Pipelines



Avoiding excavation damage through intensive data exchange between utility and construction sectors

Smarter mobility



Less disruption for professional and private road users

Real estate information



Enabling faster property transactions through smart data sharing

Technology = Solid – Personal Data Vault

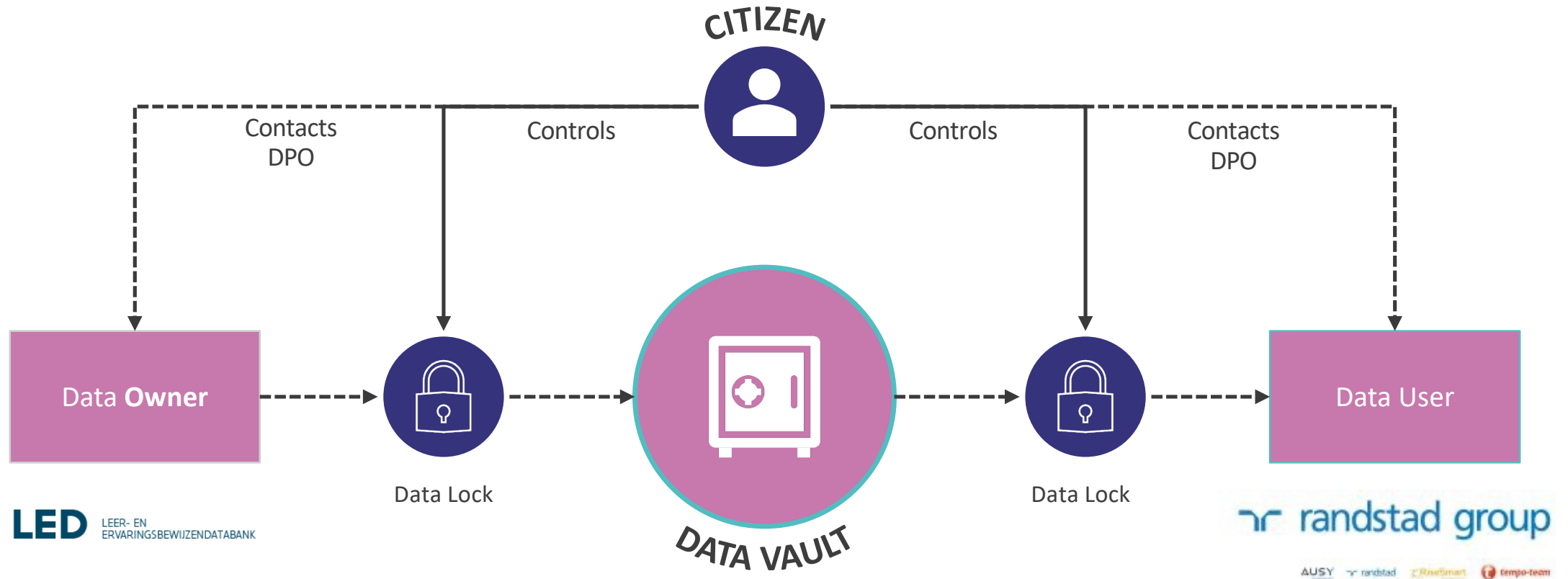

USP's Data Utility company



We ensure data collaboration

- The Data Utility company is a trusted partner to enable data collaboration
- We have no business interest in the data itself



We relieve you of the hassle of data

- Privacy and trust "by design"
- High-value data sets + personal data spaces
- Interoperability, standards, availability and scalability, ...



We are a public company

- Neutral to the private market
- Protective towards persons
- We know the way within government to be able to take legislative initiatives as well



We are strong in managing ecosystems of data



We are generic, making us better placed to facilitate cross-sectoral innovation



Strong link with European Commission and MyData, making our initiatives scalable

Overzicht use cases & releases

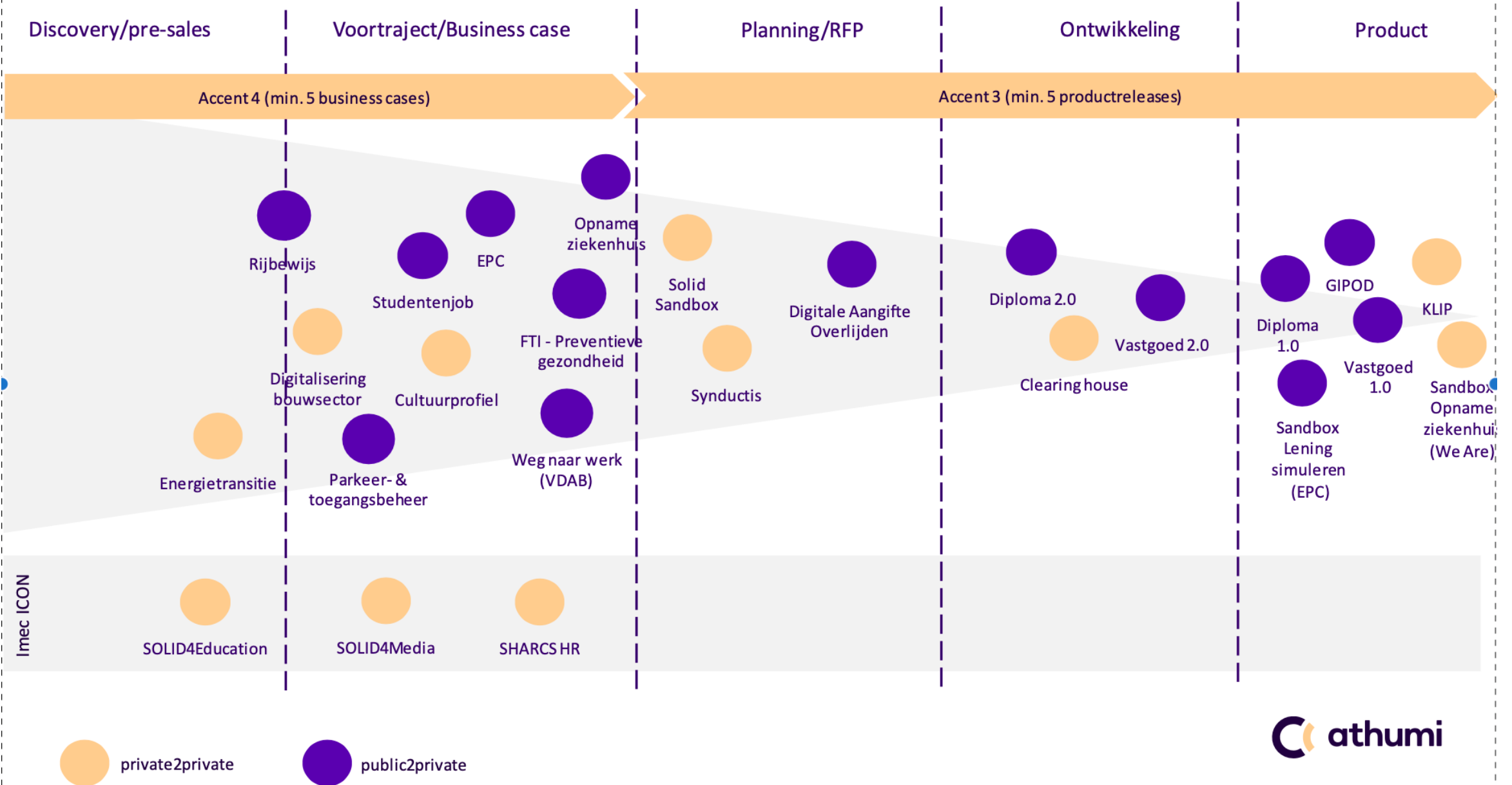

Partnerships

Klanten



Enablers



Technology



Microsoft



In discussion

Collaboration agreement

Pilot

Production

Menu

- AI: what, when, how ?

- Flanders AI Program

- Issues in 'AI in science' policies and science policy for AI

- athumi (Flanders Data Utility Company)

