

Medium-Voltage Power Conversion Systems in the Next-Generation

Hiro Akagi
Tokyo Institute of Technology

Tokyo Institute of Technology
Power Electronics Lab.



Hiro Akagi, Tokyo Institute of Technology



Tokyo Institute of Technology
Power Electronics Lab.



新幹線 (The Shinkansen)

Tokyo-Osaka : 515 km

2.5 hours at maximum speed : 270 km/h

The number of passengers : 1,323/16 cars

The fare for one way : 13,000 JPY (=110 USD)



Question

How much does one passenger pay for the
Charge of electricity from 13,000 JPY ?

Hint: 150, 750, or 1500 JPY (Gas: 130 JPY/liter)

3

Tokyo Institute of Technology
Power Electronics Lab. 

Answer

➤ **150 JPY**

✓ The maximum power of the 16 cars : 13.2 MW

✓ The total electric energy : 23 MWh

✓ The average power : $23 \text{ MWh} / 2.5 = 9.2 \text{ MW}$

✓ The number of passengers : 1,326

✓ The average power per passenger :

$$9.2 \text{ MW} / 1,326 = 7 \text{ kW}$$

✓ The total energy per passenger :

$$7 \text{ kW} \times 2.5 \text{ h} = 17.5 \text{ kWh}$$

$17.5 \text{ kWh} \times 8 \sim 10 \text{ JPY/kWh} \doteq 150 \text{ JPY}$

4

Tokyo Institute of Technology
Power Electronics Lab. 

Main Power Circuit

Nozomi series 700

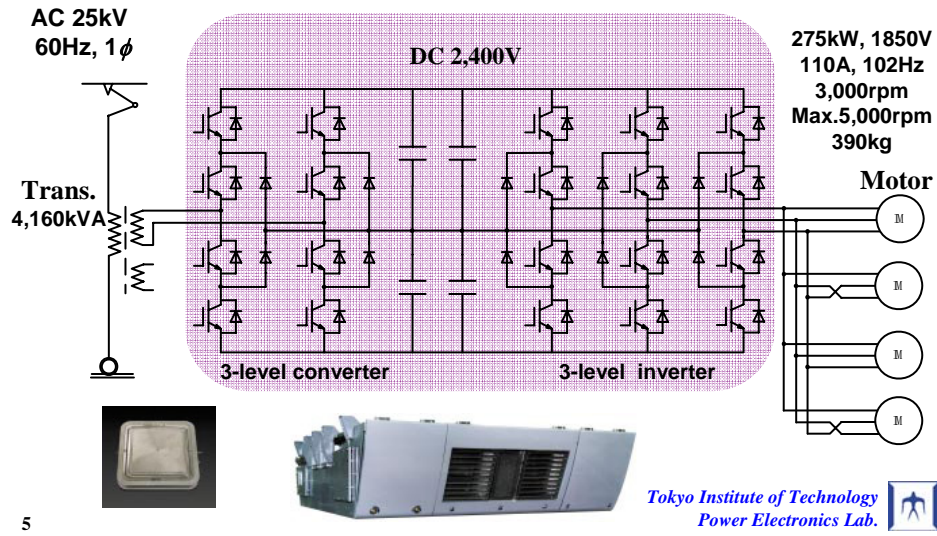

Applications of STATCOM and BTB in Japan

○ The 60-MW Electric Frequency Changer (Commissioned in 2004)

K. Kunomura, K. Yoshida, K. Ito, N. Nagayama, M. Otuki, T. Ishizaka, F. Aoyama, T. Yoshino, "Electric Frequency Converter," in *Proceedings of the 2005 International Power Electronics Conference (IPEC)*, Niigata, Japan, S71-4, 2005.

○ The 80-MVA STATCOM (Commissioned in 2004)

T. Fujii, S. Funahashi, N. Morishima, M. Azuma, H. Teramoto, N. Iio, H. Yonezawa, D. Takayama, and Y. Shinki, "A 80-MVA STATCOM for the Kanzaki Substation," in *Proceedings of the 2005 International Power Electronics Conference (IPEC)*, Niigata, Japan, S37-1, 2005.

Hiro Akagi, Tokyo Institute of Technology



Tokyo Institute of Technology
Power Electronics Lab.

7

The 60-MW Electric Frequency Changer

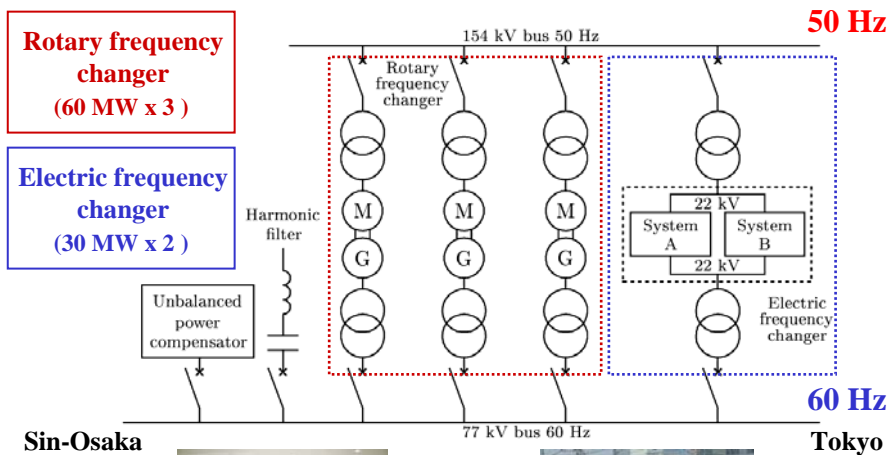

TOSHIBA



Tokyo Institute of Technology
Power Electronics Lab.

8

Circuit Configuration of 30-MW Unit

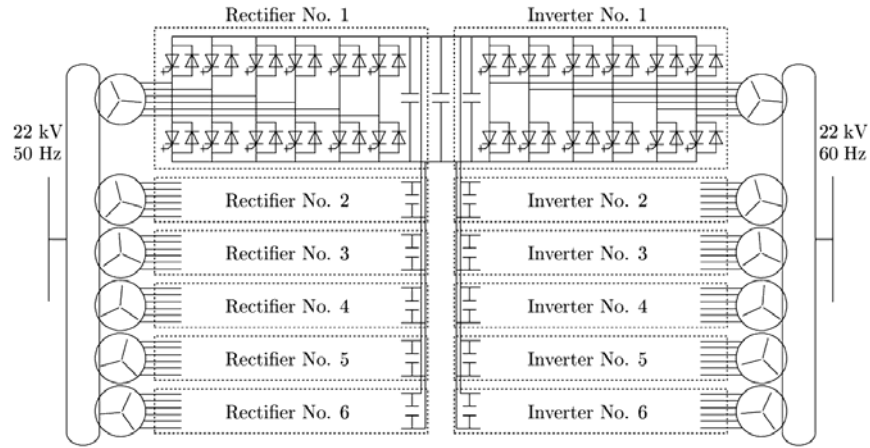

6-kV 4-kA GTOs Efficiency : 96%

TOSHIBA

9

Tokyo Institute of Technology
Power Electronics Lab.



Applications of STATCOM and BTB in Japan

○ The 60-MW Electric Frequency Changer (Commissioned in 2004)

K. Kunomura, K. Yoshida, K. Ito, N. Nagayama, M. Otuki, T. Ishizaka, F. Aoyama, T. Yoshino, "Electric Frequency Converter," in *Proceedings of the 2005 International Power Electronics Conference (IPEC)*, Niigata, Japan, S71-4, 2005.

○ The 80-MVA STATCOM (Commissioned in 2004)

T. Fujii, S. Funahashi, N. Morishima, M. Azuma, H. Teramoto, N. Iio, H. Yonezawa, D. Takayama, and Y. Shinki, "A 80-MVA STATCOM for the Kanzaki Substation," in *Proceedings of the 2005 International Power Electronics Conference (IPEC)*, Niigata, Japan, S37-1, 2005.

10

Tokyo Institute of Technology
Power Electronics Lab.



Hiro Akagi, Tokyo Institute of Technology



11

Tokyo Institute of Technology
Power Electronics Lab. 

The 80-MVA STATCOM

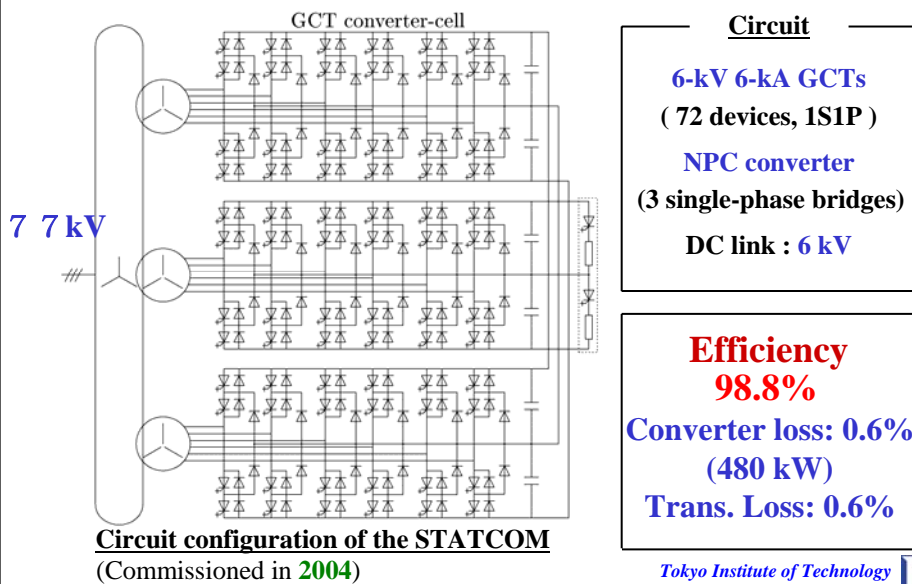

12

Tokyo Institute of Technology
Power Electronics Lab. 

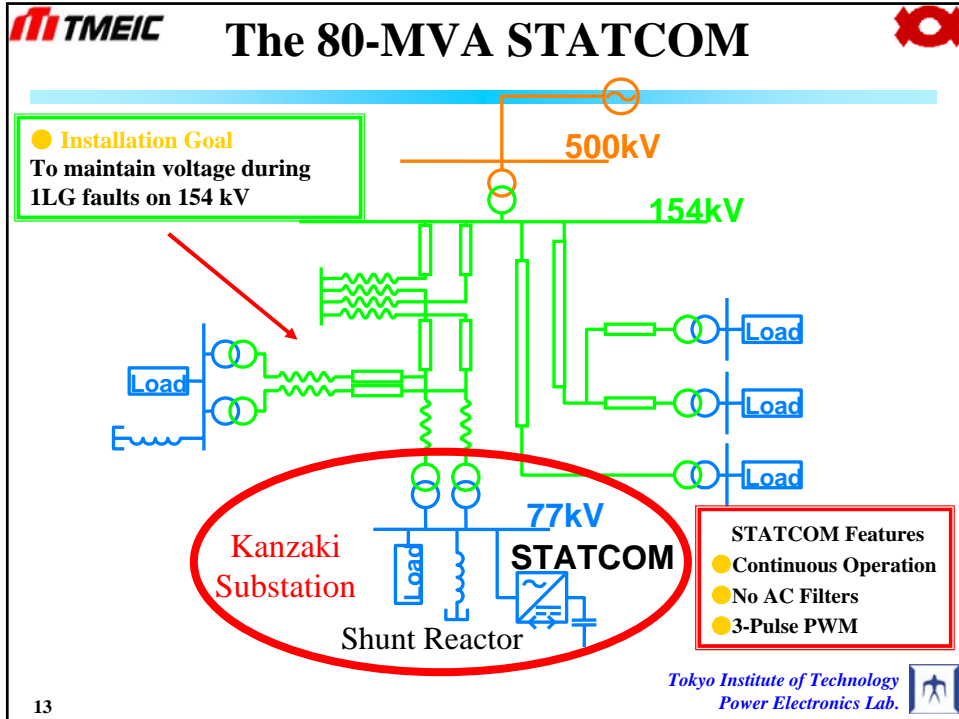

The Medium-Power Conversion System based on Bi-directional Isolated DC/DC Converters

Hiro Akagi

Tokyo Institute of Technology

DC Power Supply

1970's: Series Regulators

- Electric Isolation: **Line-Frequency Transformer**
↳ Heavy and Bulky
- Voltage Regulation: **Linear Operation**
↳ Low Efficiency

Today: Switching Regulators

- Electric Isolation: **High-Frequency Transformer**
↳ Light and Compact
- Voltage Regulation: **Switching Operation**
↳ High Efficiency

15

Tokyo Institute of Technology
Power Electronics Lab.



Why Are High-Frequency Transformers Useful?

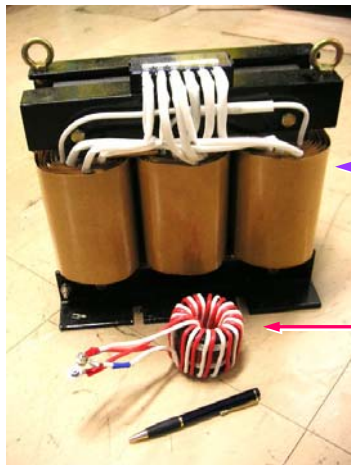

Three-phase 200-V, 5-kVA,
50-Hz Transformer

Single-phase, 250-V, 5-kVA,
20-kHz Transformer

16

Tokyo Institute of Technology
Power Electronics Lab.



Nominal System Voltages in Japan

Utility Distribution System : **6.6 kV**

Industrial Distribution System : **3.3/6.6 kV**

■ Functions of the 6.6-kV STATCOM

- Power factor correction
- Voltage regulation
- Load balancing

17

Tokyo Institute of Technology
Power Electronics Lab.



Medium-Voltage Power Conversion Systems



- 6.6-kV Distribution Feeder
 - Ⓢ STATCOM
 - Ⓢ BTB (Back-to-Back) system



© TOSHIBA TOSVERT-MV
(3.3 kV, 1,800 kW)

- Industry
 - Ⓢ 3.3-kV/6.6-kV motor drive

18

Tokyo Institute of Technology
Power Electronics Lab.



6.6-kV STATCOM for Utility and Industry

Today

1 MVA

6.6 kV

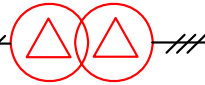

Transformer Weight : **4,000 kg**
Size : **1m × 2m × 2.5m**

Converter Weight : **1,000~2,000 kg**

Requirements : **Low Cost, Small Size, Light Weight**

**The 6.6-kV Transformerless
STATCOM**

19

Tokyo Institute of Technology
Power Electronics Lab.



Today's Medium-Voltage Motor Drives

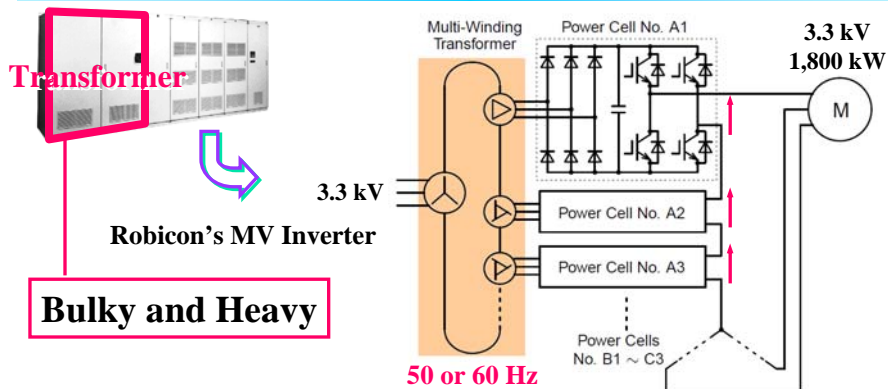

Bulky and Heavy

© P. W. Hammond, *IEEE Trans. Ind. Applicat.*, vol. 33, no. 1, pp. 202-208, 1997

■ Roles of the multi-winding transformer (50/60 Hz) :

- ☉ To supply isolated voltages to each power cell
- ☉ To reduce harmonic currents

20

Tokyo Institute of Technology
Power Electronics Lab.



Future Medium-Voltage Power Conversion

Today: Line-Frequency Transformer

Used for Voltage Matching and/or Electrical Isolation

Future: Transformerless or High-Freq. Transformer

- Transformerless: Multi-level PWM Converters
 - Diode-Clamped, Flying Capacitor, and Cascaded
- High-Freq. Trans.: Bi-Directional Isolated DC/DC Converters

Power-Electronic DC Transformers

21

The Next-Generation Motor Drive

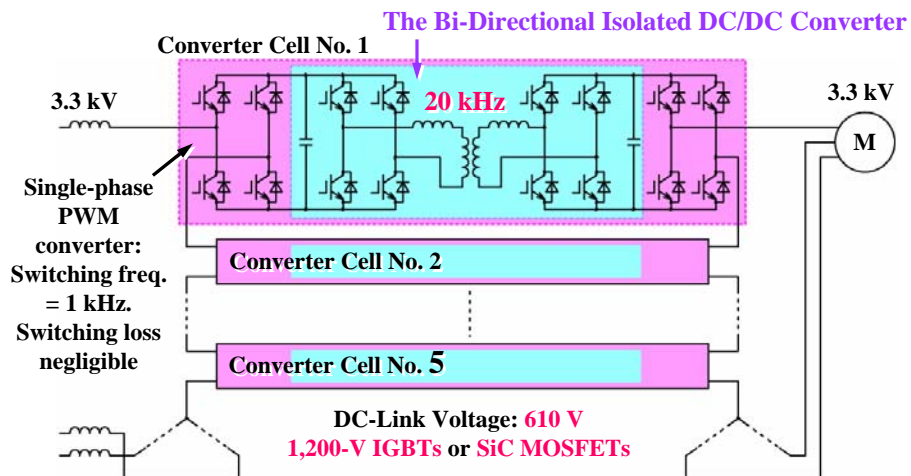

- The DC/DC converter dominates system efficiency

22

The Bi-Directional Isolated DC/DC Converter

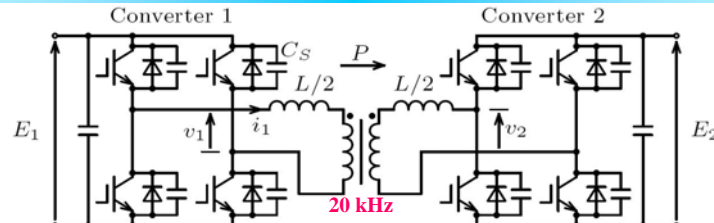

© R. W. De Doncker, et al., *IEEE Trans. Ind. Applicat.*, vol. 28, no. 6, pp. 1294-1301, 1991

	1991	2004 Winter	2010
Switching Devices	First-Generation IGBTs	Trench-Gate IGBTs	SiC MOSFETs
Core Material in Transformer	Ferrite	Finemet™* (Hitachi Metals)	New Material?
Efficiency (DC to DC)	90 ~ 92%	97%	Over 99%

* Nano-crystalline soft-magnetic material
23

Tokyo Institute of Technology
Power Electronics Lab.



The Experimental Circuit for Loss Analysis

The Overall Loss Fed by the 350-V DC Source

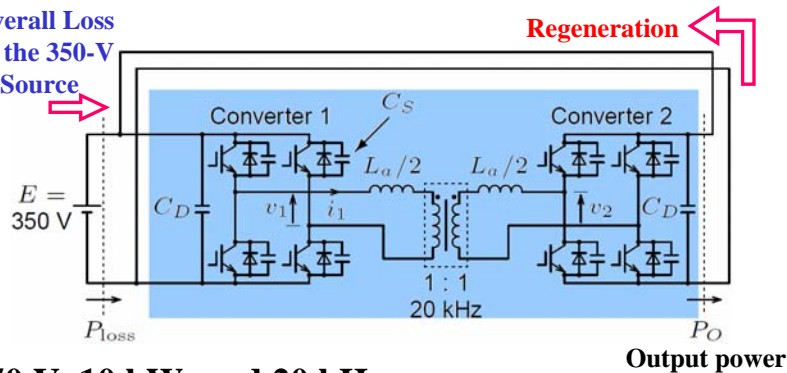

- 350 V, 10 kW, and 20 kHz
- Output DC power P_O is regenerated to Input DC terminals.
- Loss analysis estimates the possibility of SiC devices.

Tokyo Institute of Technology
Power Electronics Lab.



24

Experimental Setup



Controllable
via a personal
computer

25

ogy
Power Electronics Lab. 

Experimental Setup

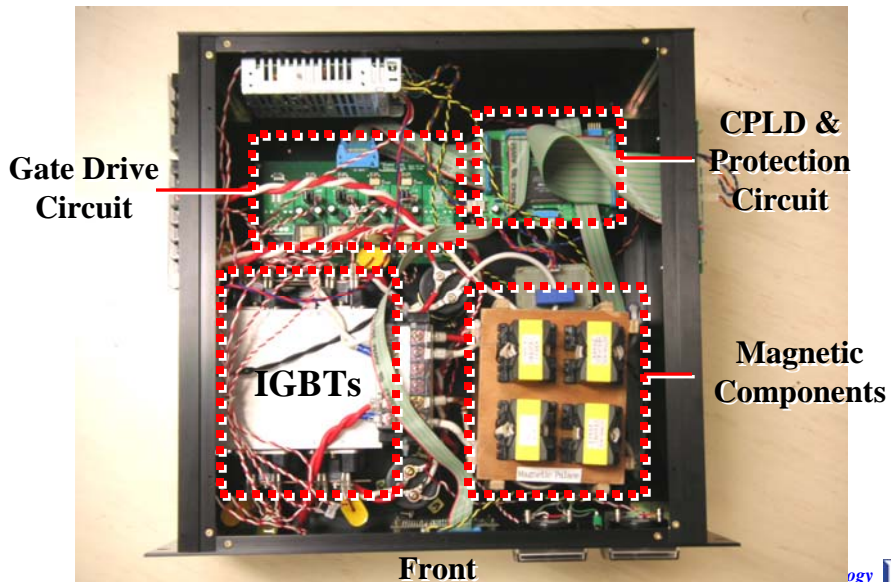

26

ogy
Power Electronics Lab. 

Operation Principle

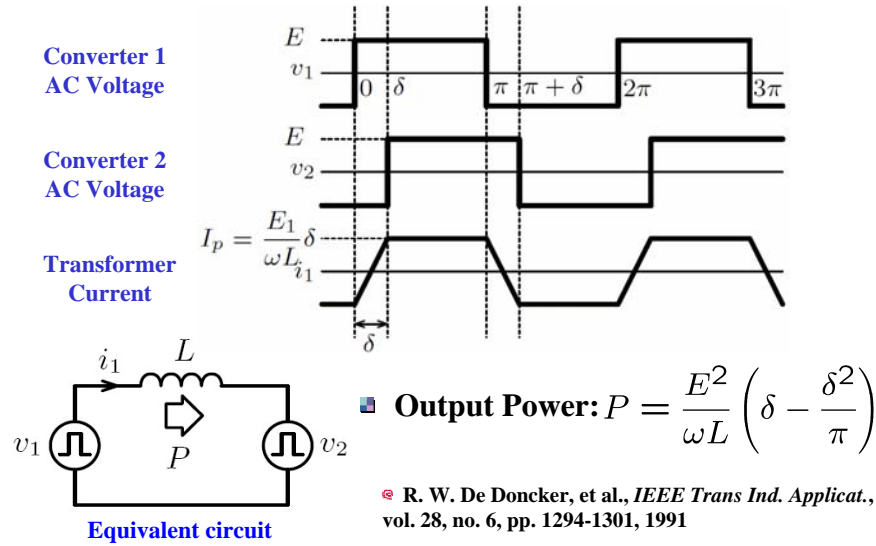

(L = transformer leakage and external inductors)

Tokyo Institute of Technology
Power Electronics Lab.

27

Experimental Waveforms at 10 kW

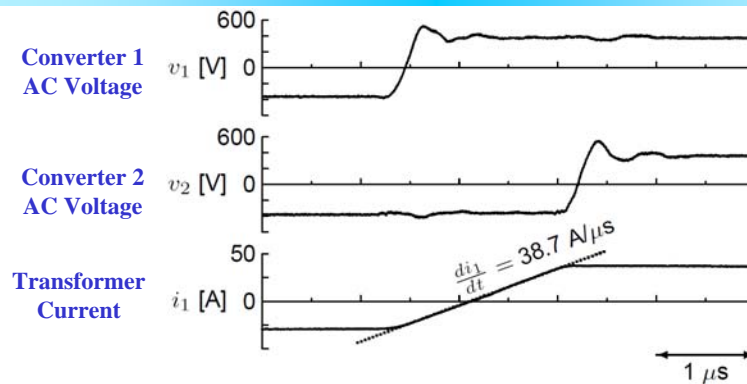

- $L = 18.6 \mu\text{H}$ and the phase shift: $\delta = 13 \text{ deg}$.
- Switching frequency: $f = 20 \text{ kHz}$
- di_1/dt values can be used in loss analysis.

Tokyo Institute of Technology
Power Electronics Lab.

28

Power P_O , Efficiency η , and Loss P_{loss}

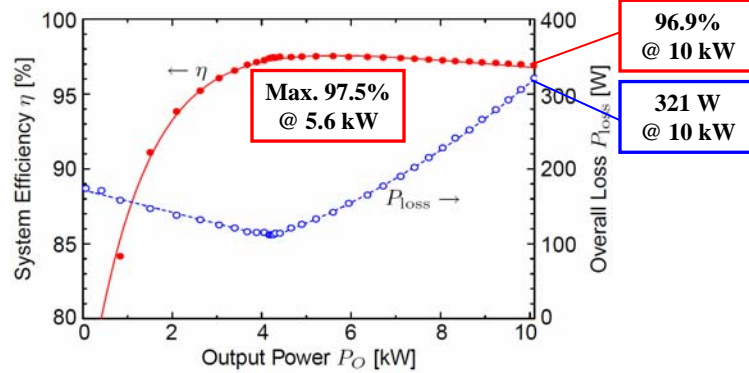

- Overall Efficiency (DC to DC): Max. **97.5%**
- $P_{\text{loss}} = 321 \text{ W}$ @ $P_O = 10 \text{ kW}$
- What causes the 321-W loss?**

Loss Analysis Result at 10 kW

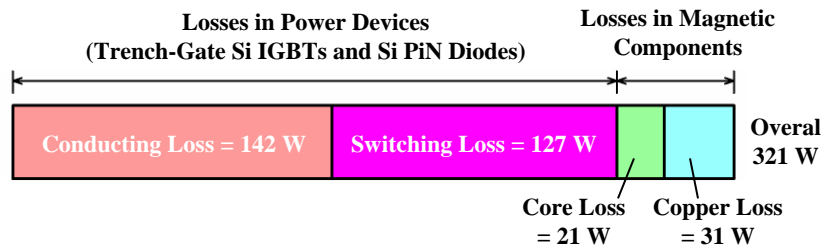

- Power-device loss (=269 W) is dominant in 321 W**
- When SiC-MOSFETs are used:**
Overall Loss $P_{\text{loss}} = 28 \text{ W} + 13 \text{ W} + 21 \text{ W} + 31 \text{ W}$
 $= 93 \text{ W}$ ($\eta = 99.1\%$)
- Assuming that the conducting loss is reduced to 20% and the switching loss is reduced to 10%, compared to Si IGBTs.

Source: Arai and Yoshida: "Fundamentals and Applications of SiC devices," Ohmsha, 2003 (in Japanese)

Applications and Markets

6.6-kV Distribution Line
STATCOM
BTB System

Traction
Commuter Train (1.5 kV)
Shinkansen (25 kV)

Industry
3.3-kV/6.6-kV
Motor Drive

UPS

**Distribution
Generation**

- Various application fields
- Energy conservation and distributed power generation: The market will continue to grow.

Tokyo Institute of Technology
Power Electronics Lab.



31

A Medium-Voltage Transformerless Cascade PWM STATCOM with Star-Configuration

Hiro Akagi

Tokyo Institute of Technology

Tokyo Institute of Technology
Power Electronics Lab.



6.6-kV 1-MVA Cascade PWM STATCOM

General Features

- No Transformer
- Higher Voltage Levels
- Split DC Capacitors
- Voltage Imbalance

Design Example

- Cascade Number : $N = 6$
- 13 level in line-to-neutral
- 25 level in line-to-line
- 72 IGBTs: 1.7-kV, 200-A
- DC Voltage : 900-1,000V

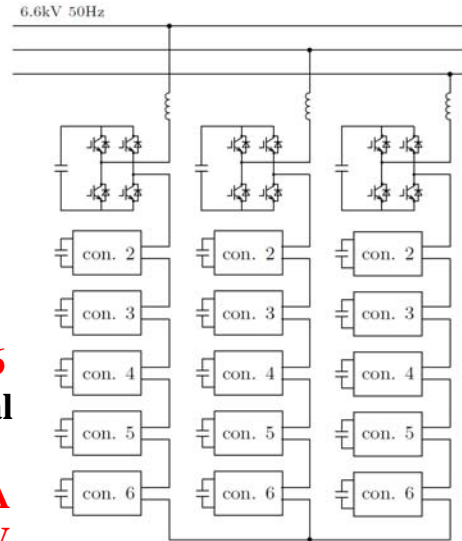

Tokyo Institute of Technology
Power Electronics Lab.

33

Control of Cascade STATCOM

Pulse-Width Modulation

- @ Quick Response
- @ 6.6-kV in Japan
- @ Difficult Voltage Balancing
- No Practical Method

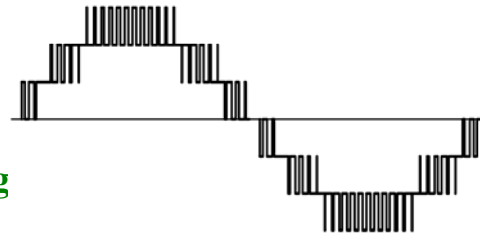

Staircase Modulation

- @ Slow Response
- @ 13.8-kV in USA
- @ Easy Voltage Balancing
- Lai and Peng, IEEE Trans. on IA, 1996

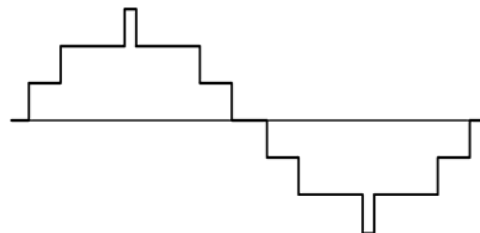

Tokyo Institute of Technology
Power Electronics Lab.

34

200-V 30-A 10-kVA Down-Scaled Model

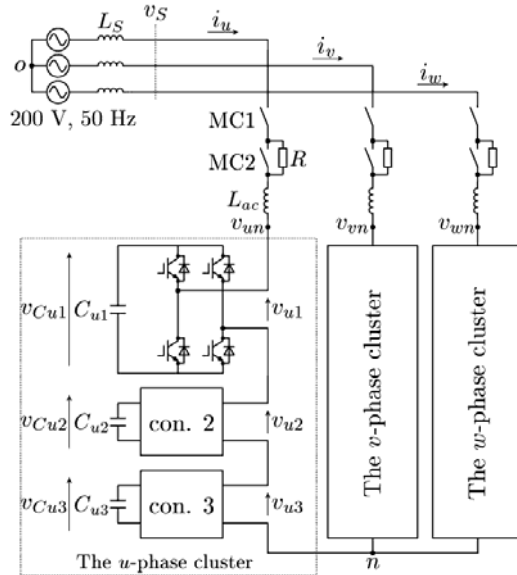

Cascade Number $N = 3$

7-level in line-to-neutral

13-level in line-to-line

Phase-Shifted PWM

Carrier frequency: 1 kHz

Equiv. frequency: 6 kHz

$L_S = 0.4\%$ (40 mH)

$L_{ac} = 10\%$ (1.2 mH)

$H = 36$ ms ($v_C = 70$ V)

$C = 16.4$ mF

Tokyo Institute of Technology
Power Electronics Lab.



35

Three Phase-Shifted Carrier Signals

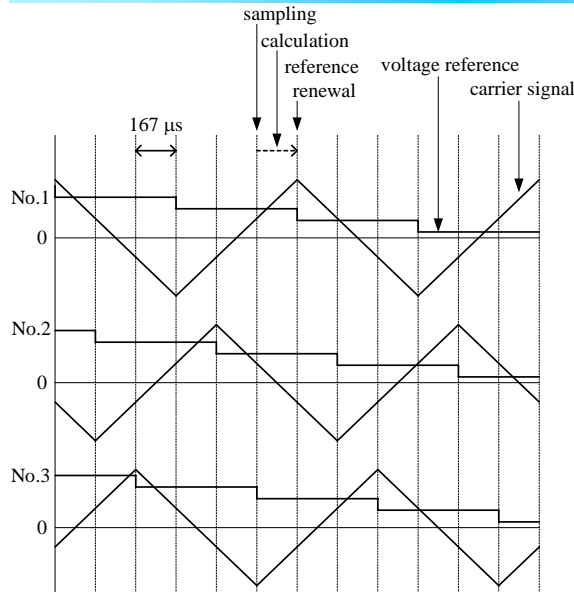

Synchronous Sampling

Sampling frequency :

6 kHz (= 1 kHz x 2 x 3)

Sampling point:

every top and bottom

period : $500/3 = 0.167$ ms

Reference Renewal

at every top and bottom

of each carrier signal

renewal period: 0.5 ms

calculation time: 0.167 ms

Tokyo Institute of Technology
Power Electronics Lab.



36

Control of 200-V Down-Scaled Model

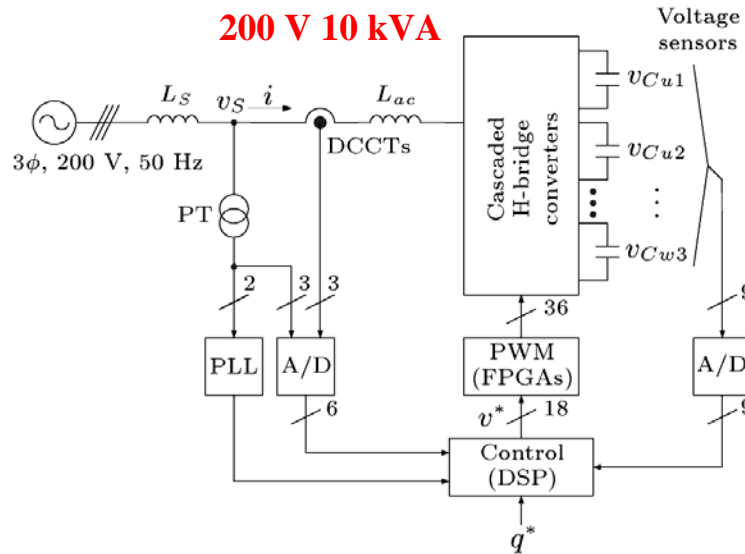

37

Control Block Diagram

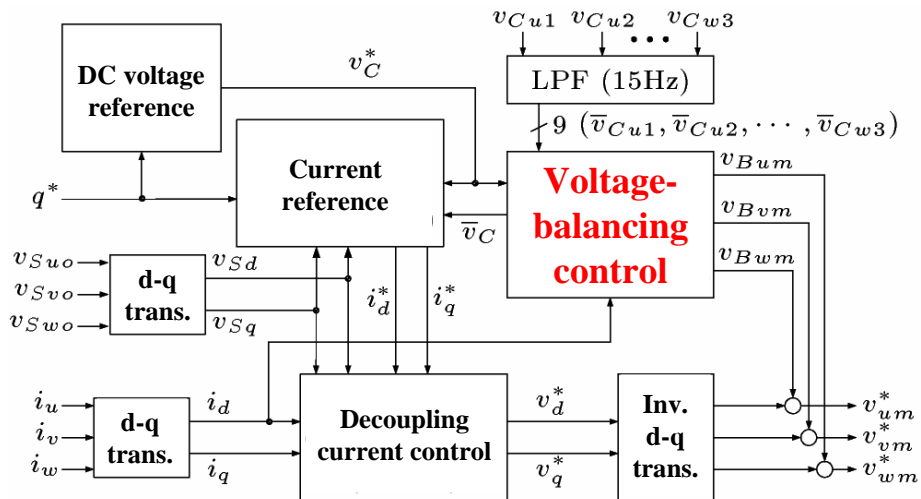

38

DC-Capacitor Voltage Control

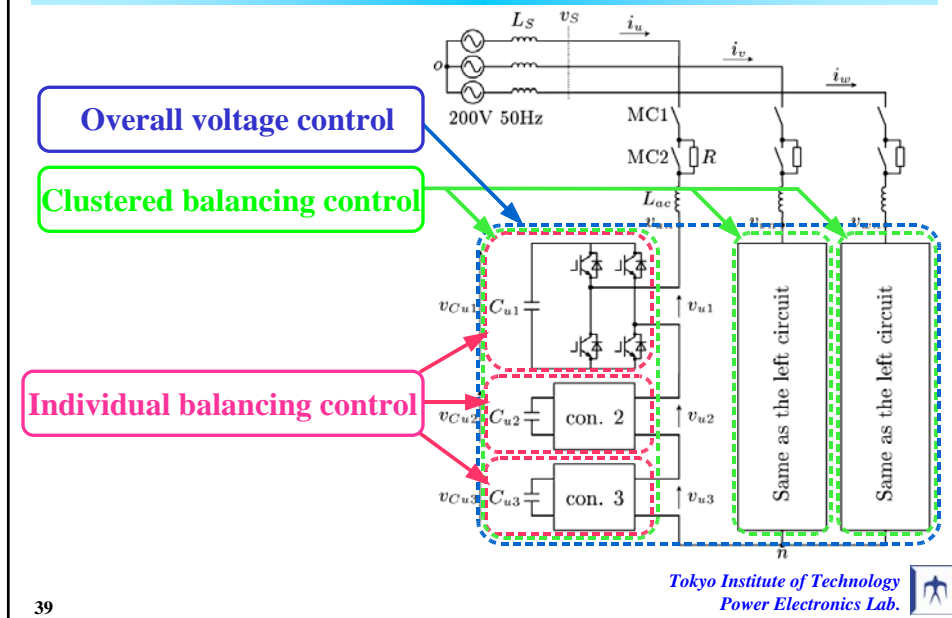

39

Overall Voltage Control

- **Control of the dc mean voltage of the nine capacitors**
- **Like a three-phase PWM converter**
- **d-q axis current control**

u-phase dc mean voltage

$$\bar{v}_{Cu} = \frac{1}{3} (\bar{v}_{Cu1} + \bar{v}_{Cu2} + \bar{v}_{Cu3})$$

Overall dc mean voltage

$$\bar{v}_C = \frac{1}{3} (\bar{v}_{Cu} + \bar{v}_{Cv} + \bar{v}_{Cw})$$

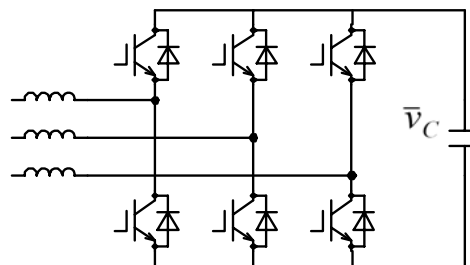

Tokyo Institute of Technology
Power Electronics Lab.

40

Clustered Balancing Control

- Balancing of dc mean voltages between three clusters
- Like three single-phase converters
- d-axis voltage control, independent of three clusters

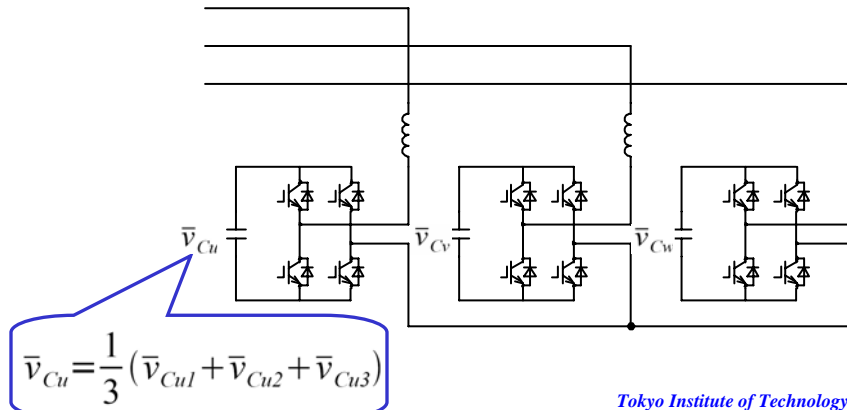

41

Tokyo Institute of Technology
Power Electronics Lab.

Individual Balancing Control

- Balancing of three dc mean voltages in each cluster
- Like a single-phase cascaded PWM converter
- q-axis voltage control, independent of three clusters

**No Interference with
Clustered Balancing Control**

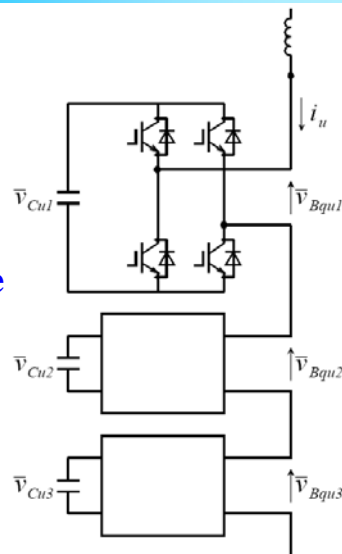

42

Tokyo Institute of Technology
Power Electronics Lab.

200-V 30-A 10-kVA Down-Scaled Model

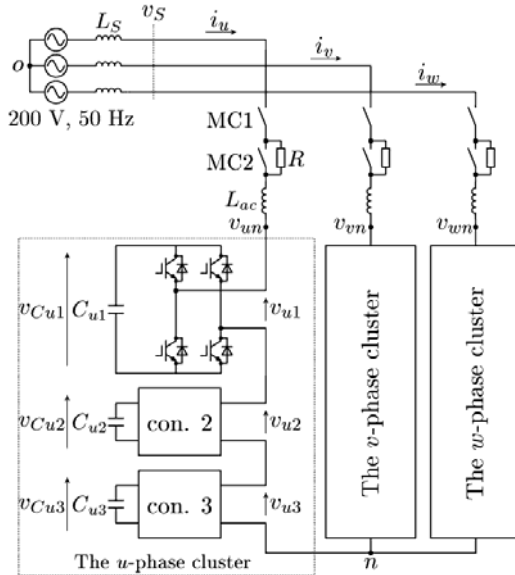

Cascade Number $N = 3$

7-level in line-to-neutral

13-level in line-to-line

Phase-Shifted Sine PWM

Carrier frequency: 1 kHz

Equiv. frequency: 6 kHz

$L_S = 0.4\%$ (40 mH)

$L_{ac} = 10\%$ (1.2 mH)

$H = 36$ ms ($v_C = 70$ V)

$C = 16.4$ mF

43

Tokyo Institute of Technology
Power Electronics Lab.



From Inductive To Capacitive Operation

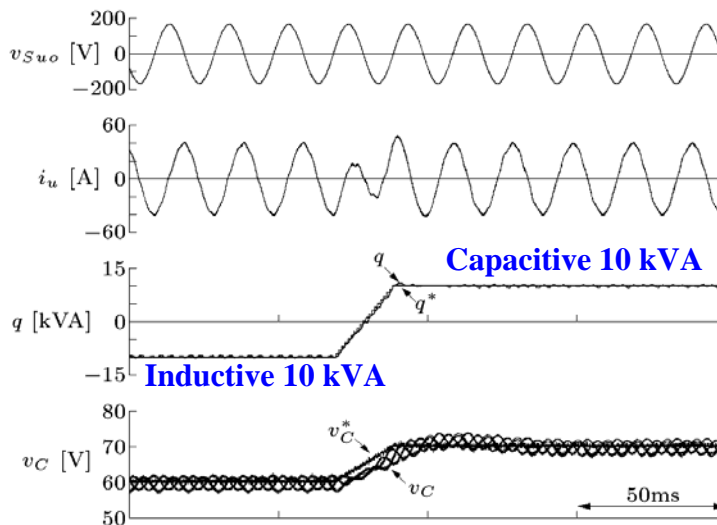

DC Voltage Control between 60 and 70 V

44

Tokyo Institute of Technology
Power Electronics Lab.



Effect of Clustered Balancing Control

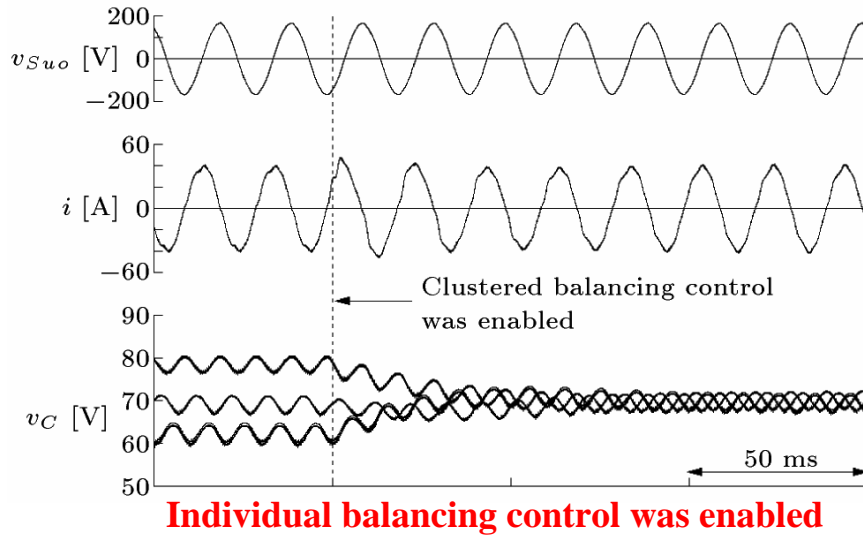

Individual balancing control was enabled

Tokyo Institute of Technology
Power Electronics Lab.



45

Effect of Individual Balancing Control

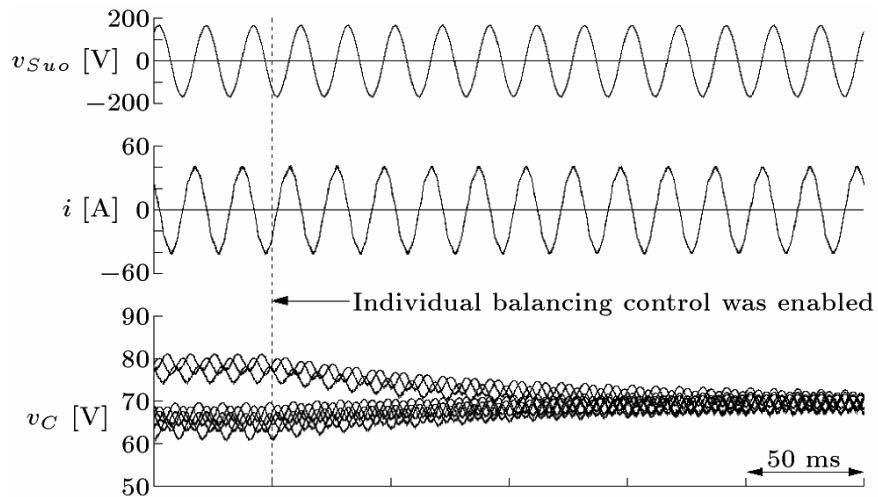

Clustered balancing control was enabled

Tokyo Institute of Technology
Power Electronics Lab.



46

Start-up Procedure

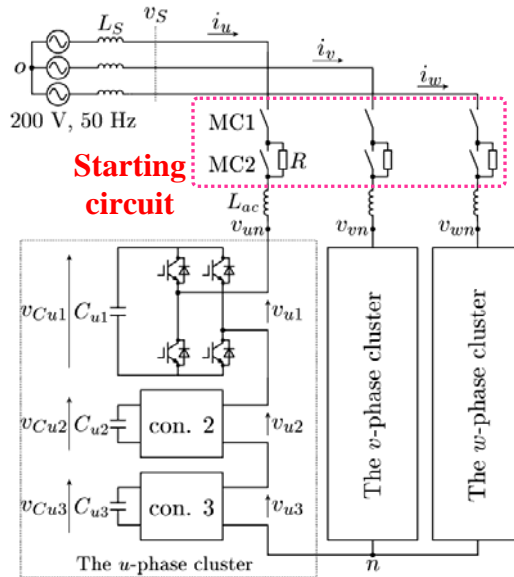

Starting circuit

1. MC1 was turned on
2. Charged up via resistor
3. MC2 was turned on
4. Switching was started

No start-up circuit on each dc side

Experimental Waveforms During Starting

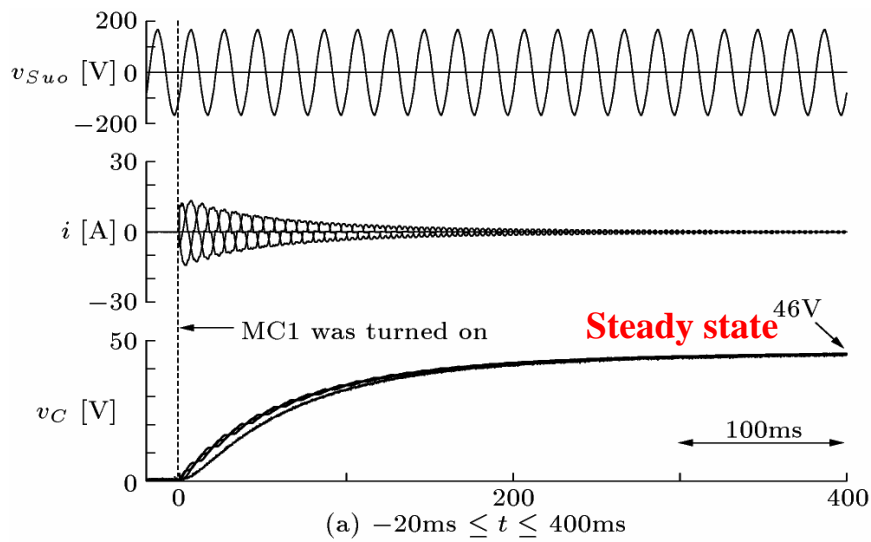

Experimental Waveforms During Starting

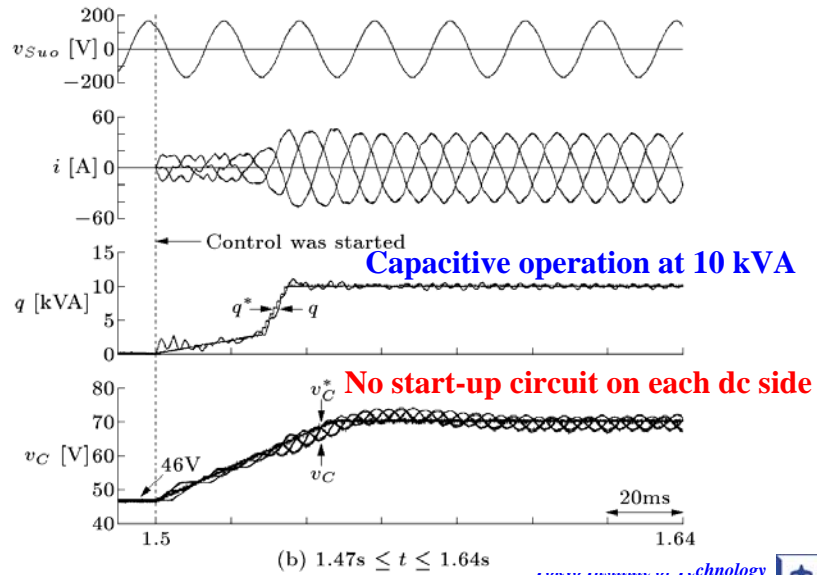

49

Advanced Technology
Power Electronics Lab.



Capacitive Operation at 10 kVA

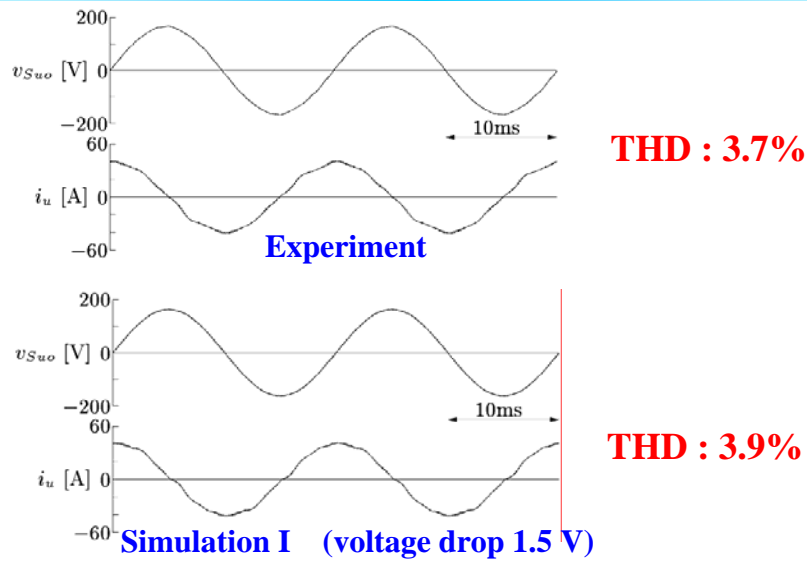

50

Tokyo Institute of Technology
Power Electronics Lab.



Capacitive Operation at 10 kVA

- Ⓢ DC Voltage of the 6.6-kV System : 1 kV
- Ⓢ Voltage Drop in 1.7-kV IGBT/Diode : 2.5 V (0.25%)
- Ⓢ Equivalent to 0.17 V in a DC Voltage of 70 V

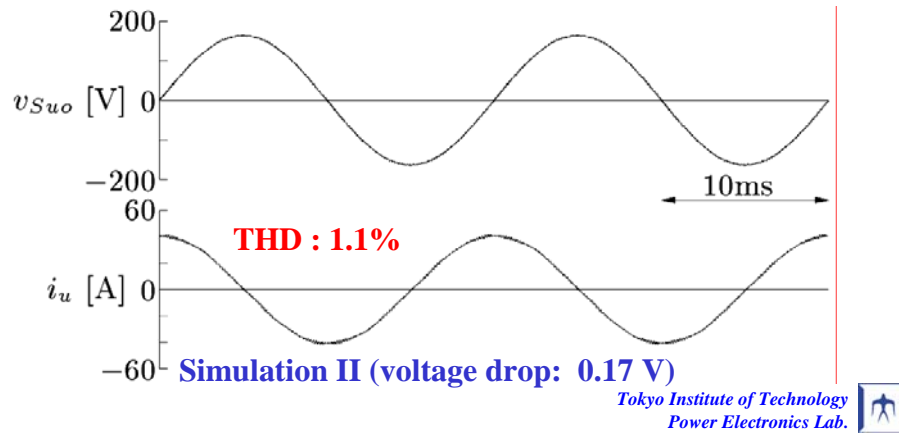

Conclusions

- 6.6-kV Transformerless Cascade STATCOM based on Phase-Shifted Sinusoidal PWM
- 200-V 10-kVA Down-Scaled Laboratory Model with Star-Configuration
- Experimental Verification of Voltage Balancing
Combination of Clustered Balancing Control with Individual Balancing Control

Easy Expansion into Higher Voltage Levels

52

Tokyo Institute of Technology
Power Electronics Lab.